



CONGREGATION SHEARITH ISRAEL

PROPOSED MIXED USE BUILDING
AUGUST 15, 2005

Platt Byard Dovell White
Architects LLP

STEPHEN TILLY, Architect

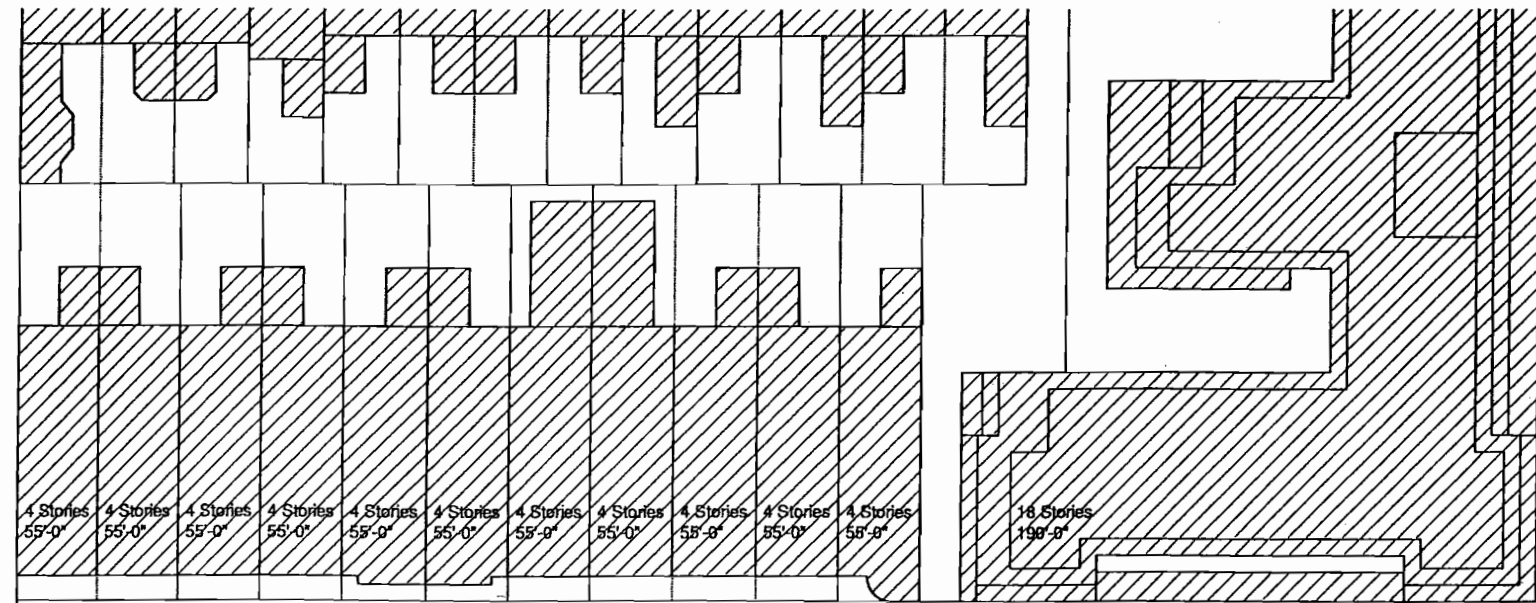

70th STREET

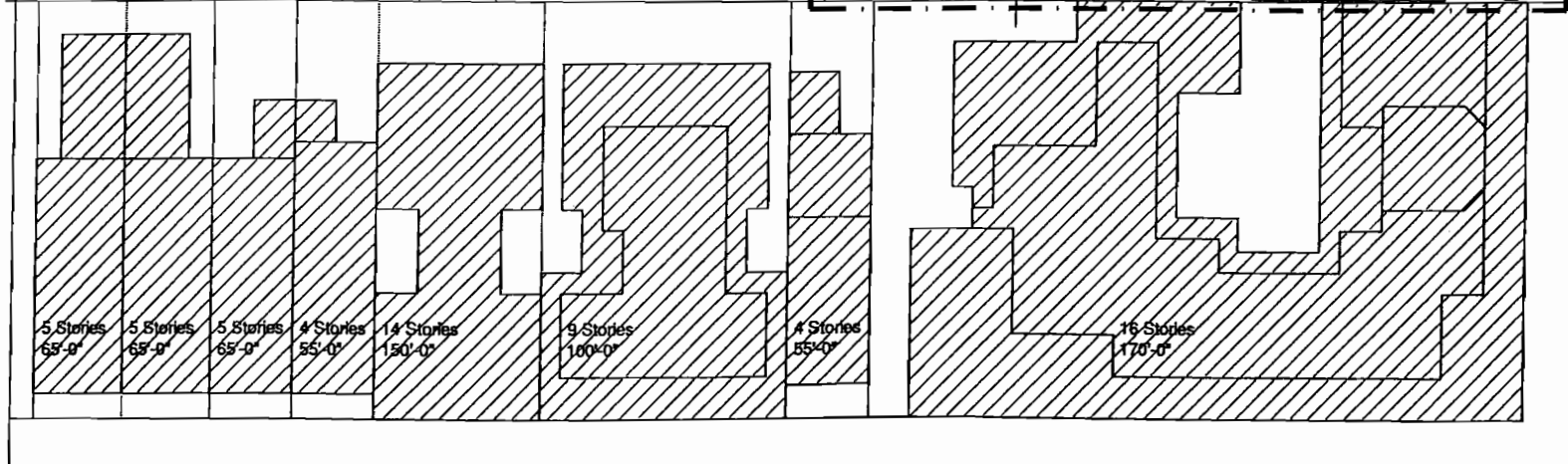
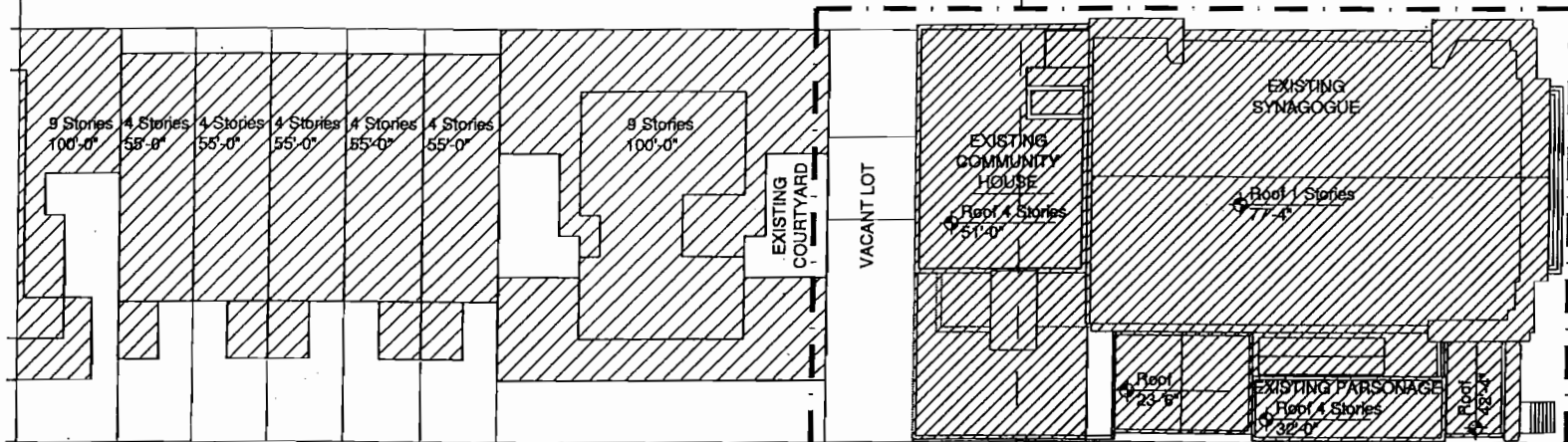

CENTRAL PARK WEST

CENTRAL PARK

NOTE: EXISTING BUILDING HEIGHTS IN NUMBER OF STORIES FURNISHED FROM SANBORN MAPS

10 WEST 70th ST.

PLATT BYARD DOVELL WHITE ARCHITECTS LLP STEPHEN TILLY, Architect

EXISTING SITE PLAN AUGUST 15, 2005



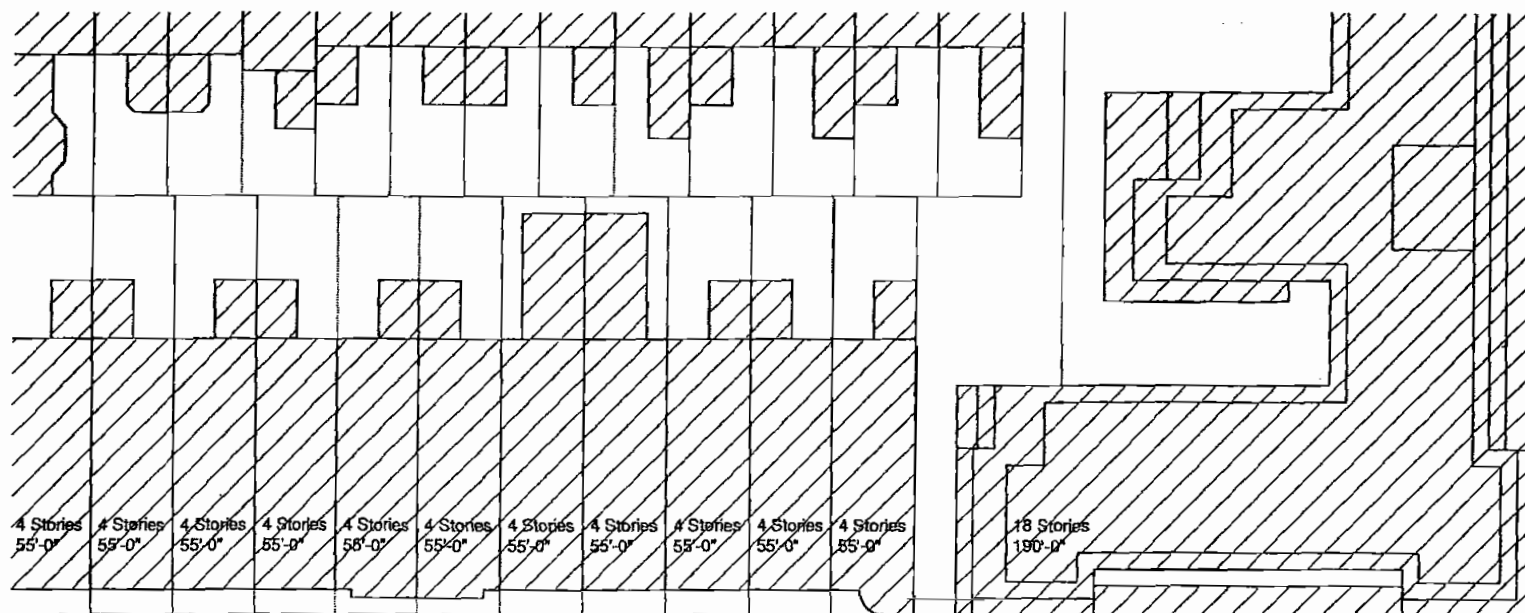

70th STREET

B8B R10A

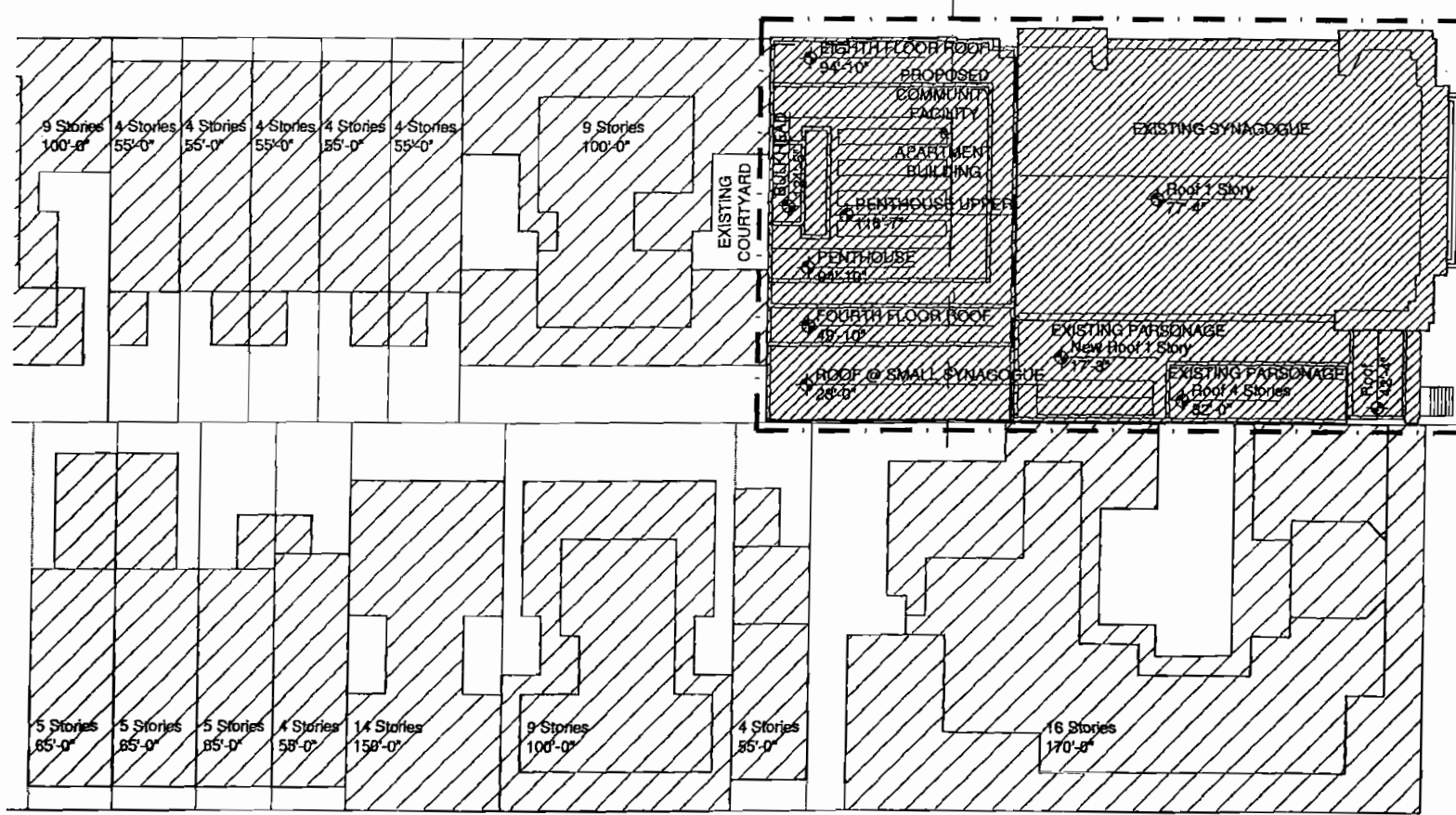

CENTRAL PARK WEST

CENTRAL PARK

NOTE: EXISTING BUILDING HEIGHTS IN NUMBER OF STORIES FURNISHED FROM SANBORN MAPS

10 WEST 70th ST.

PLATT BYARD DOVELL WHITE ARCHITECTS LLP STEPHEN TILLY, Architect

PROPOSED SITE PLAN

AUGUST 15, 2005



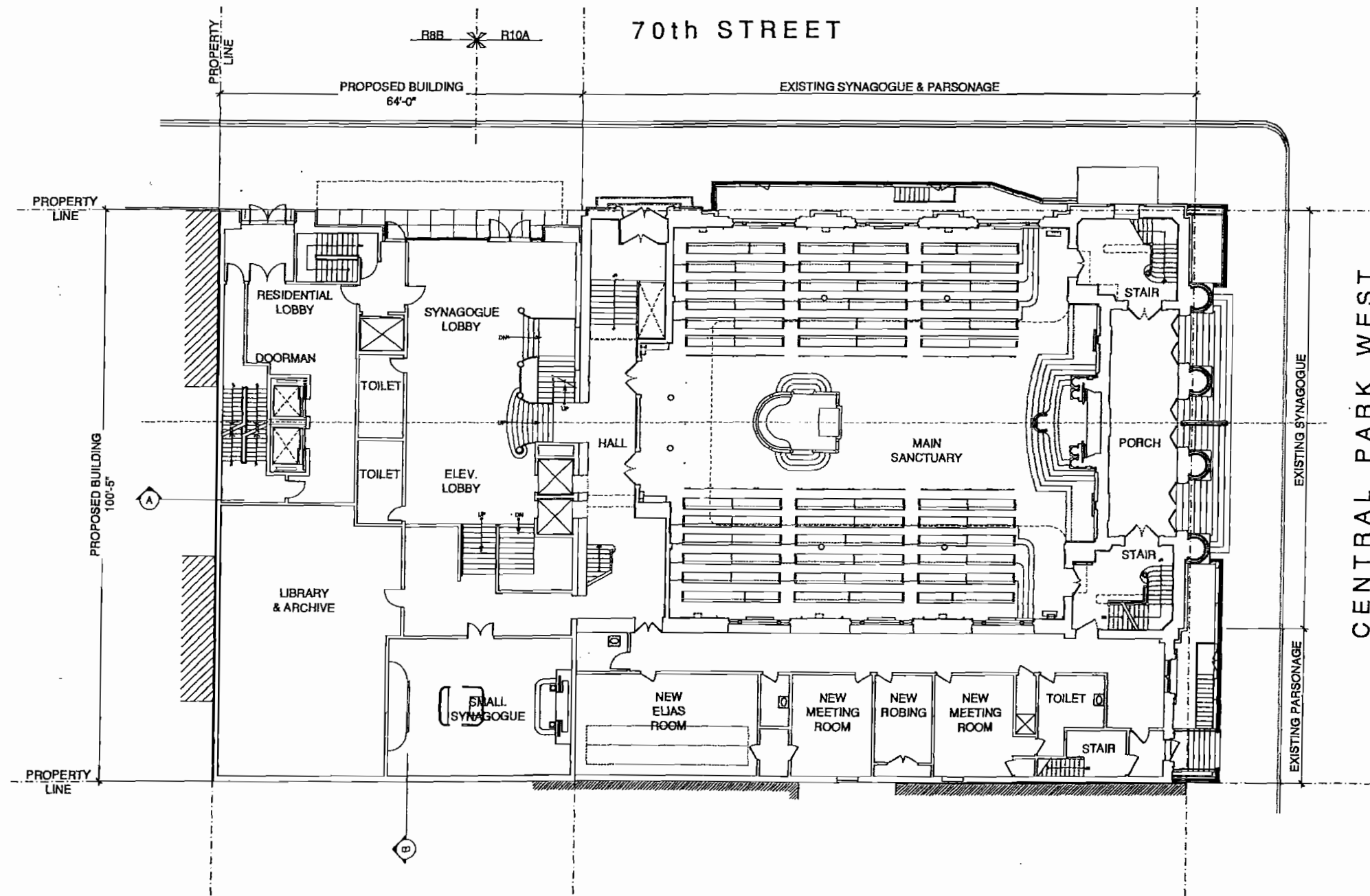

CENTRAL PARK WEST

NOTE: INTERIOR PARTITIONS FOR ILLUSTRATIVE PURPOSES ONLY

10 WEST 70th ST.

PLATT BYARD DOVELL WHITE ARCHITECTS LLP STEPHEN TILLY, Architect

PROPOSED GROUND FLOOR PLAN

AUGUST 15, 2005



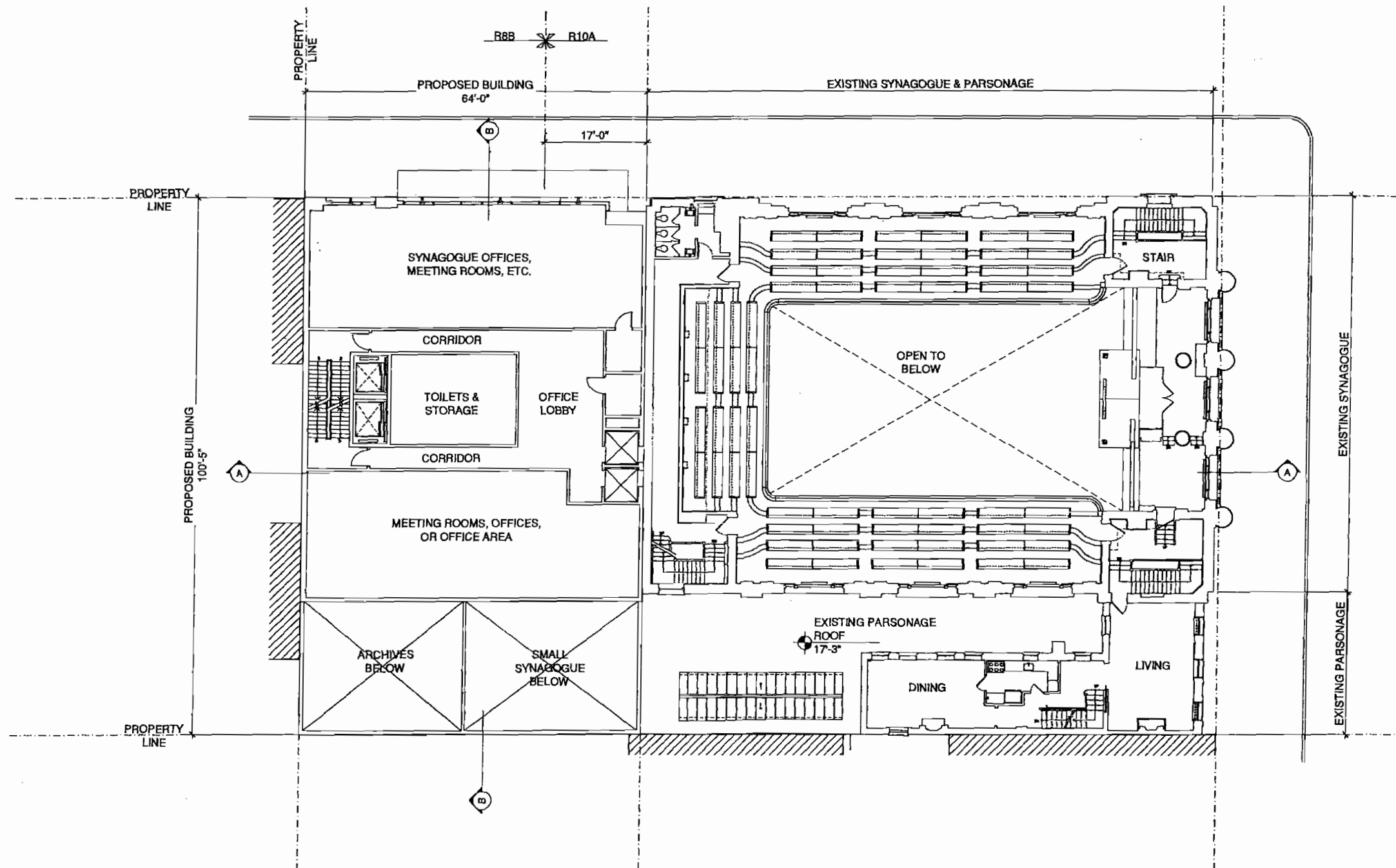

NOTE: INTERIOR PARTITIONS FOR ILLUSTRATIVE PURPOSES ONLY

10 WEST 70th ST.

PLATT BYARD DOVELL WHITE ARCHITECTS LLP STEPHEN TILLY, Architect

PROPOSED SECOND FLOOR PLAN

AUGUST 15, 2005



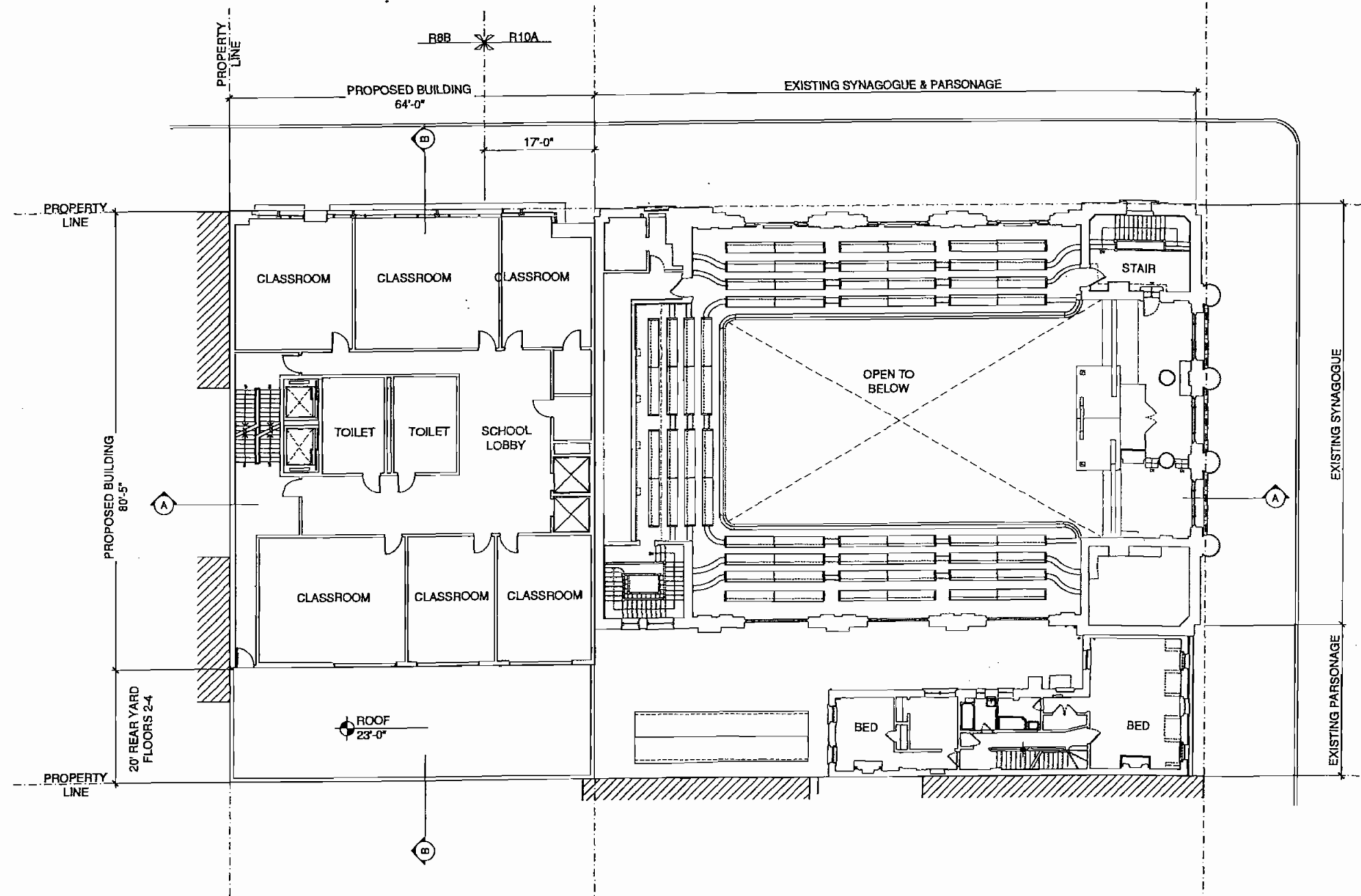

NOTE: INTERIOR PARTITIONS FOR ILLUSTRATIVE PURPOSES ONLY

10 WEST 70th ST.

PLATT BYARD DOVELL WHITE ARCHITECTS LLP
STEPHEN TILLY, Architect

PROPOSED THIRD FLOOR PLAN

AUGUST 15, 2005



NOTE: MIXED USE
FLOOR SHOWN-
CODE ISSUES
NOT VERIFIED

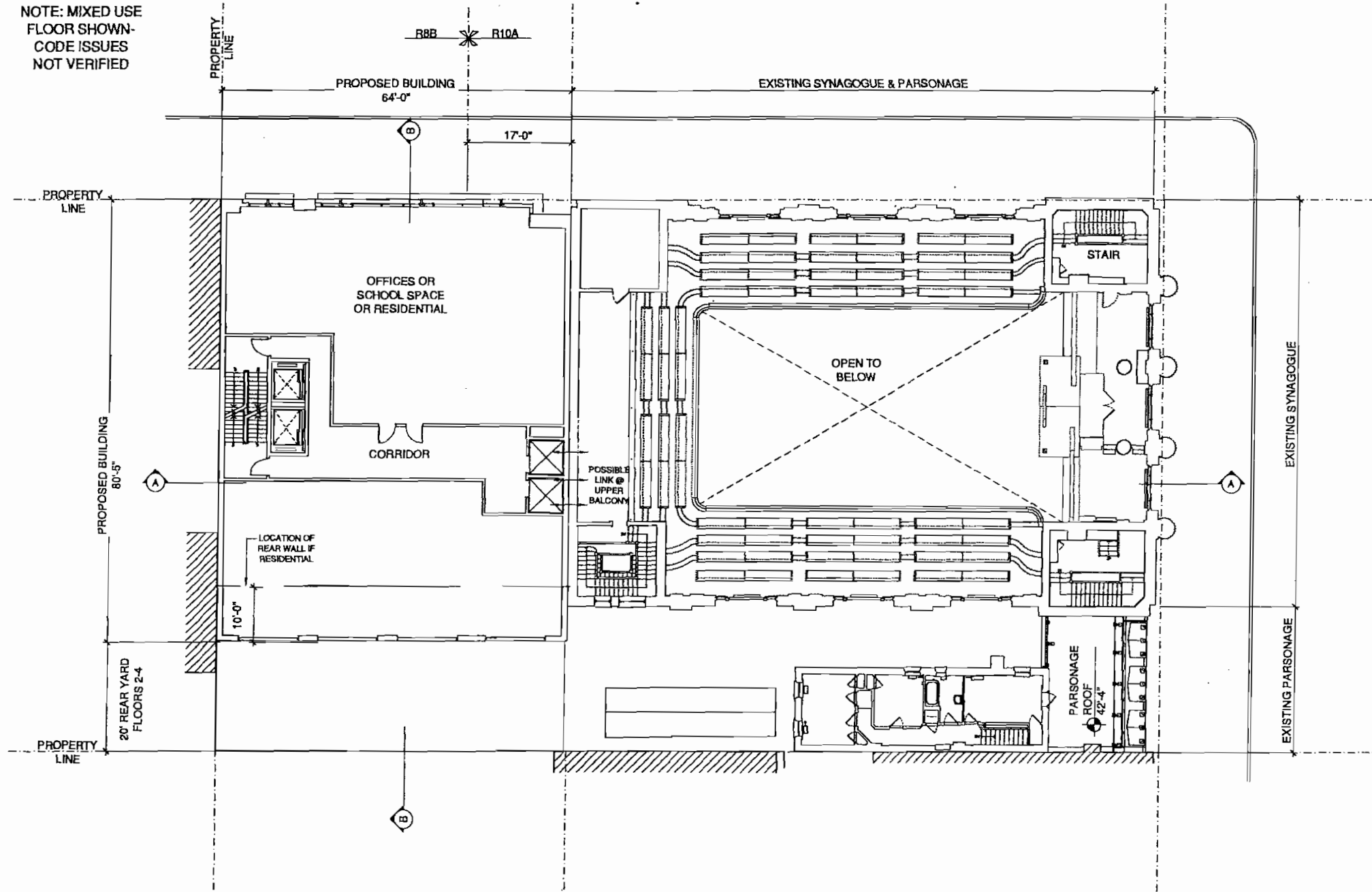

NOTE: INTERIOR PARTITIONS
FOR ILLUSTRATIVE
PURPOSES ONLY

10 WEST 70th ST.

PLATT BYARD DOVELL WHITE ARCHITECTS LLP
STEPHEN TILLY, Architect

PROPOSED FOURTH FLOOR PLAN

AUGUST 15, 2005



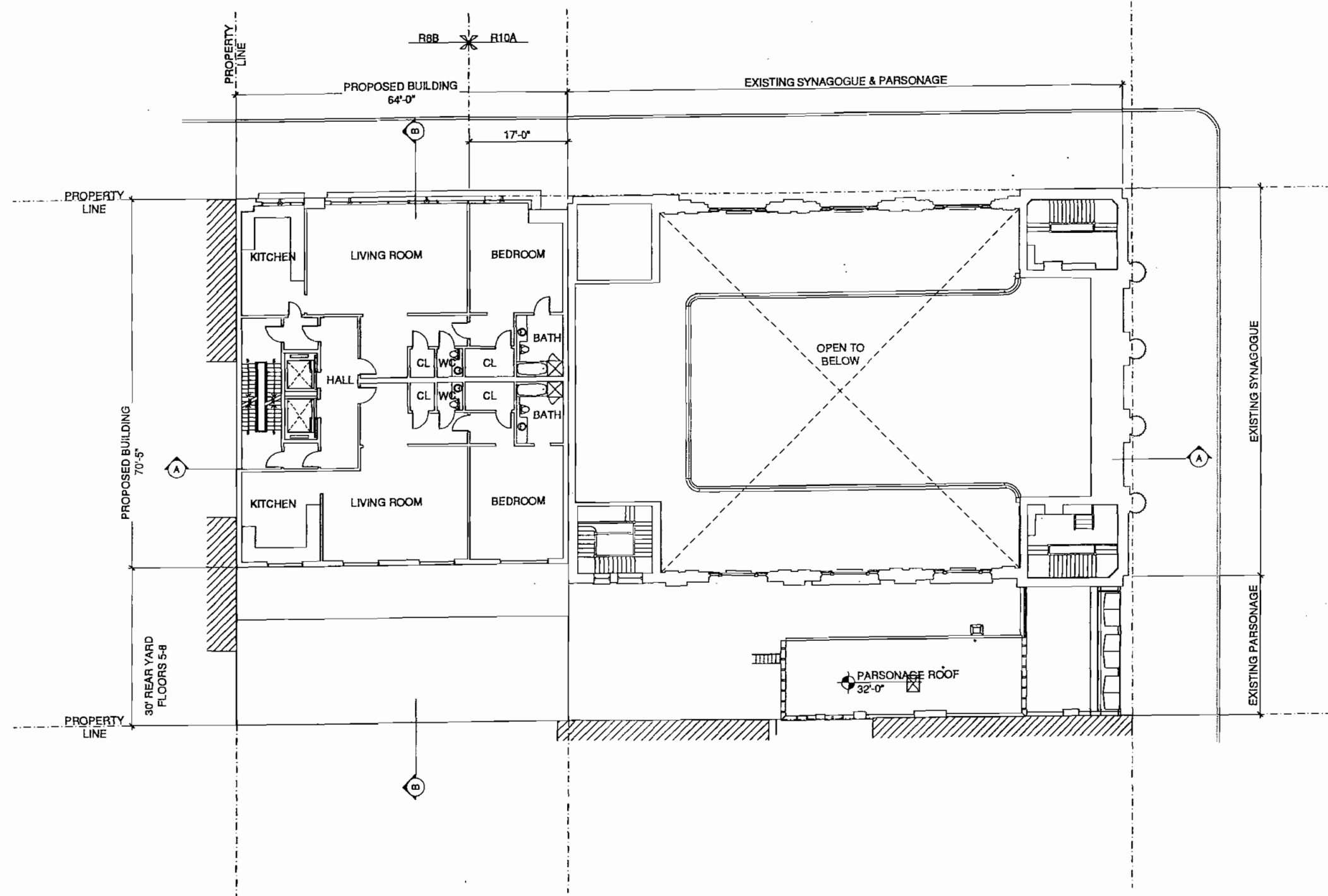

NOTE: INTERIOR PARTITIONS
FOR ILLUSTRATIVE
PURPOSES ONLY

10 WEST 70th ST.

PLATT BYARD DOVELL WHITE STEPHEN TILLY, Architect
ARCHITECTS LLP

PROPOSED FIFTH FLOOR PLAN

AUGUST 15, 2005



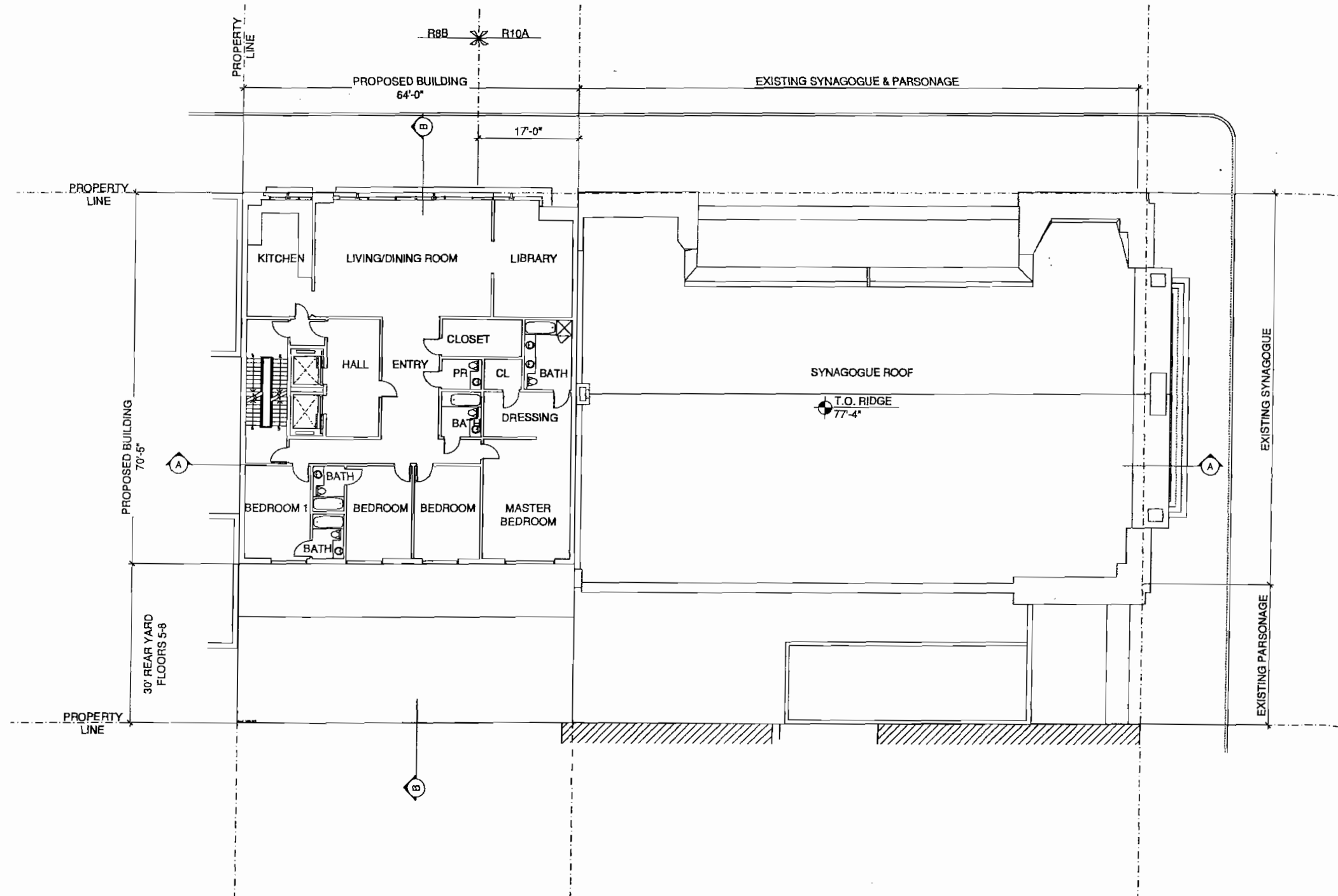

NOTE: INTERIOR PARTITIONS FOR ILLUSTRATIVE PURPOSES ONLY

10 WEST 70th ST.

PLATT BYARD DOVELL WHITE ARCHITECTS LLP STEPHEN TILLY, Architect

PROPOSED SIXTH FLOOR PLAN

AUGUST 15, 2005



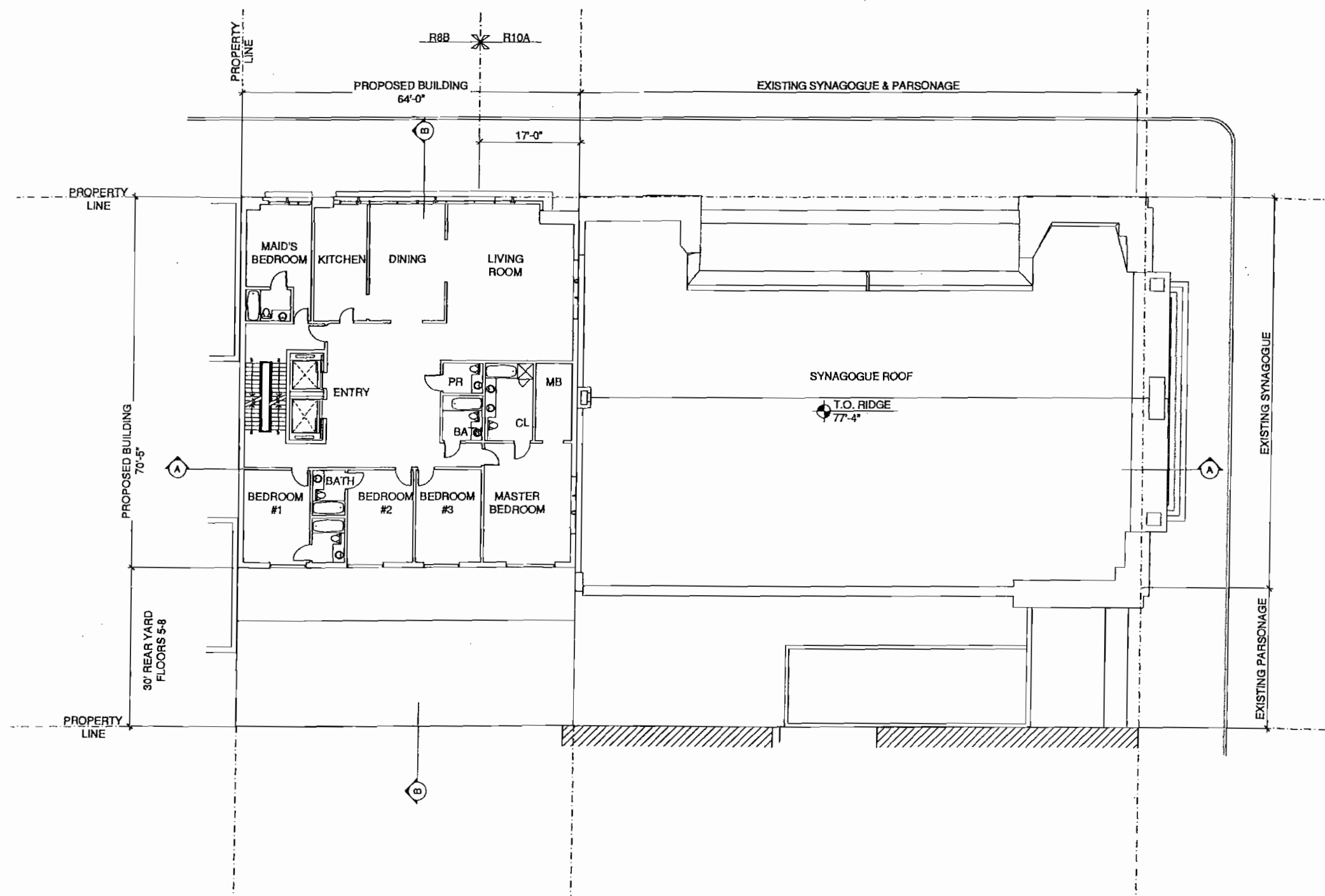

NOTE: INTERIOR PARTITIONS FOR ILLUSTRATIVE PURPOSES ONLY

10 WEST 70th ST.
 PLATT BYARD DOVELL WHITE STEPHEN TILLY, Architect
 ARCHITECTS LLP

PROPOSED SEVENTH FLOOR PLAN
 AUGUST 15, 2005



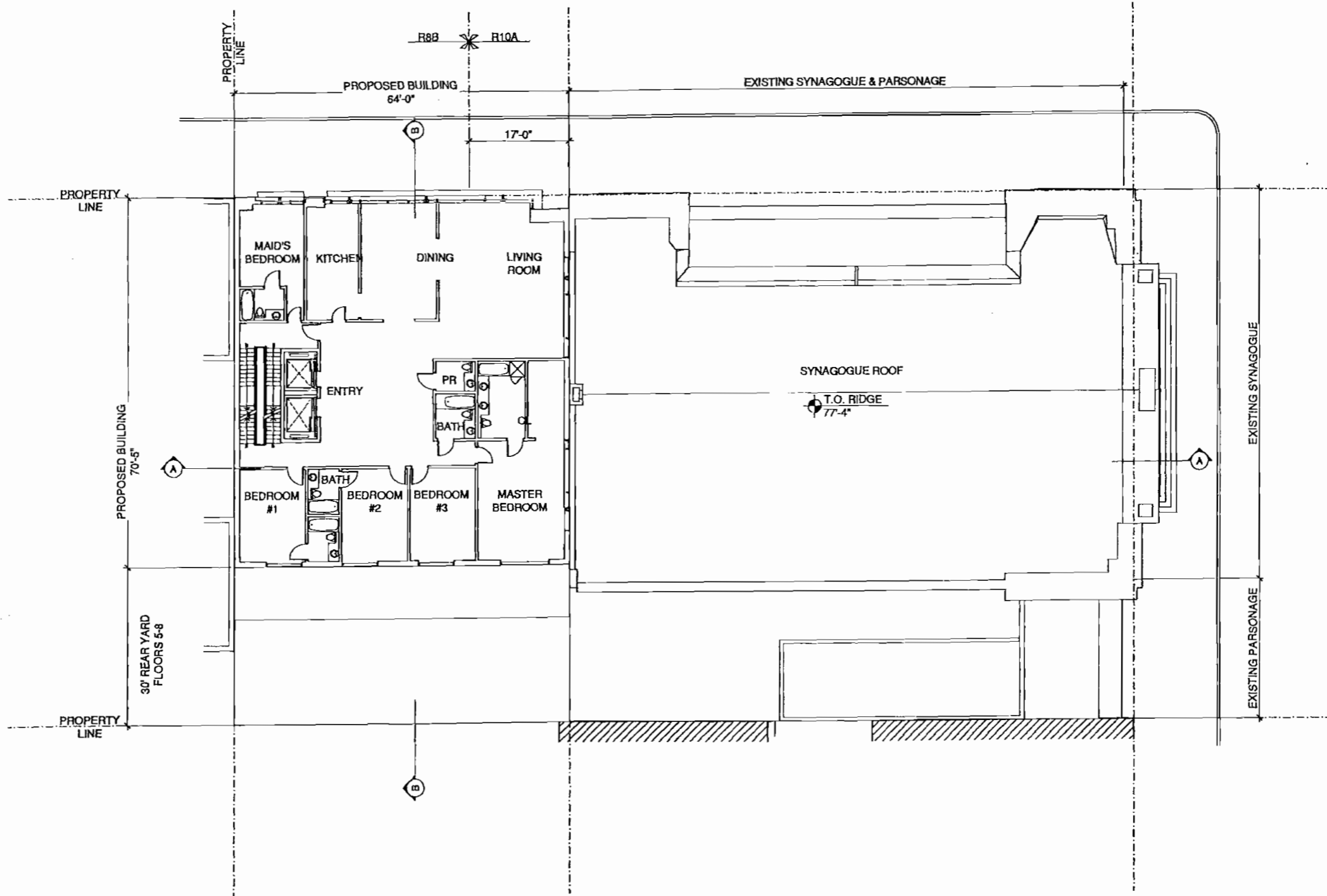

NOTE: INTERIOR PARTITIONS FOR ILLUSTRATIVE PURPOSES ONLY

10 WEST 70th ST.

PLATT BYARD DOVELL WHITE ARCHITECTS LLP STEPHEN TILLY, Architect

PROPOSED EIGHTH FLOOR PLAN

AUGUST 15, 2005



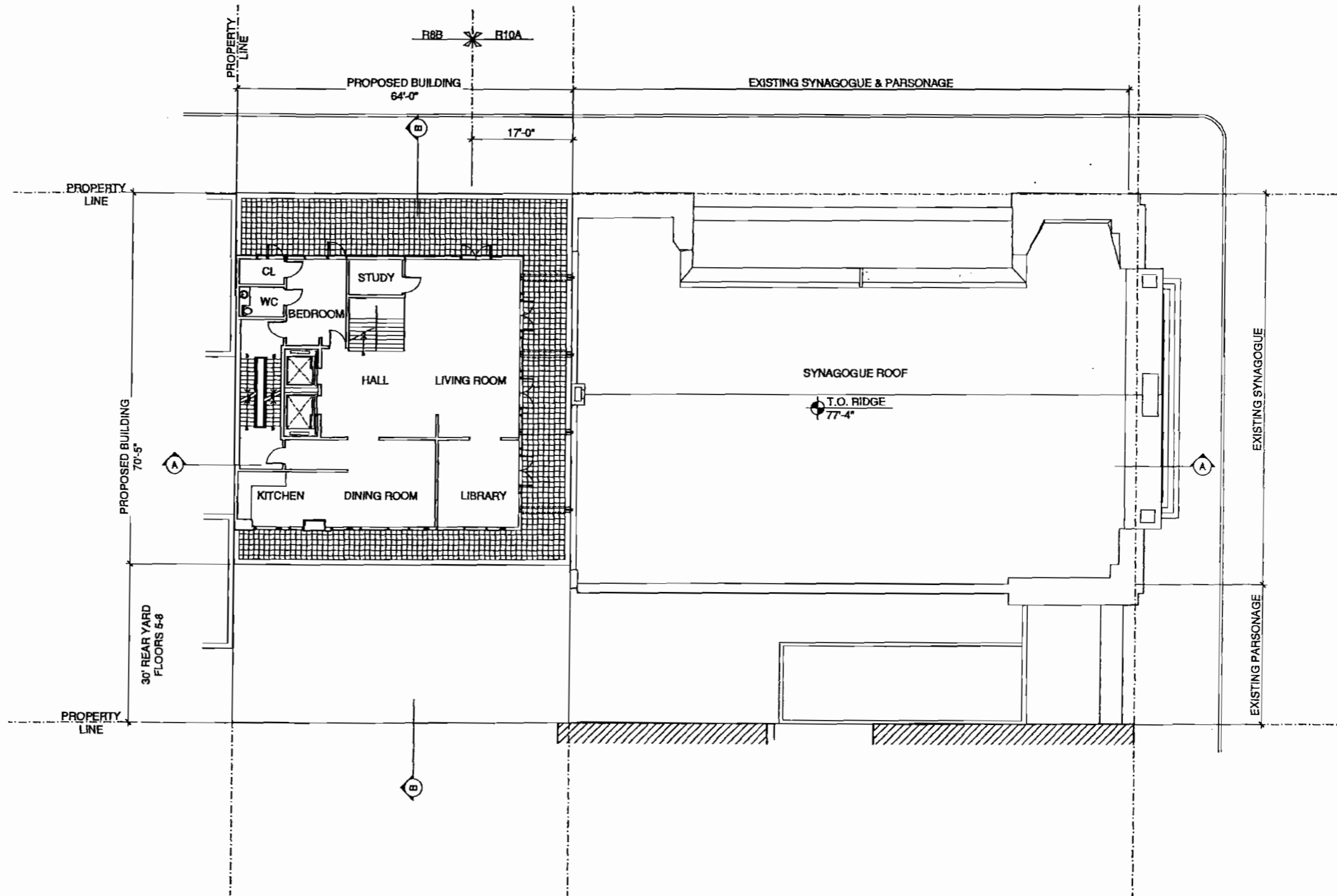

NOTE: INTERIOR PARTITIONS FOR ILLUSTRATIVE PURPOSES ONLY

10 WEST 70th ST.
 PLATT BYARD DOVELL WHITE ARCHITECTS LLP
 STEPHEN TILLY, Architect

PROPOSED PENTHOUSE- LOWER LEVEL FLOOR PLAN

AUGUST 15, 2005



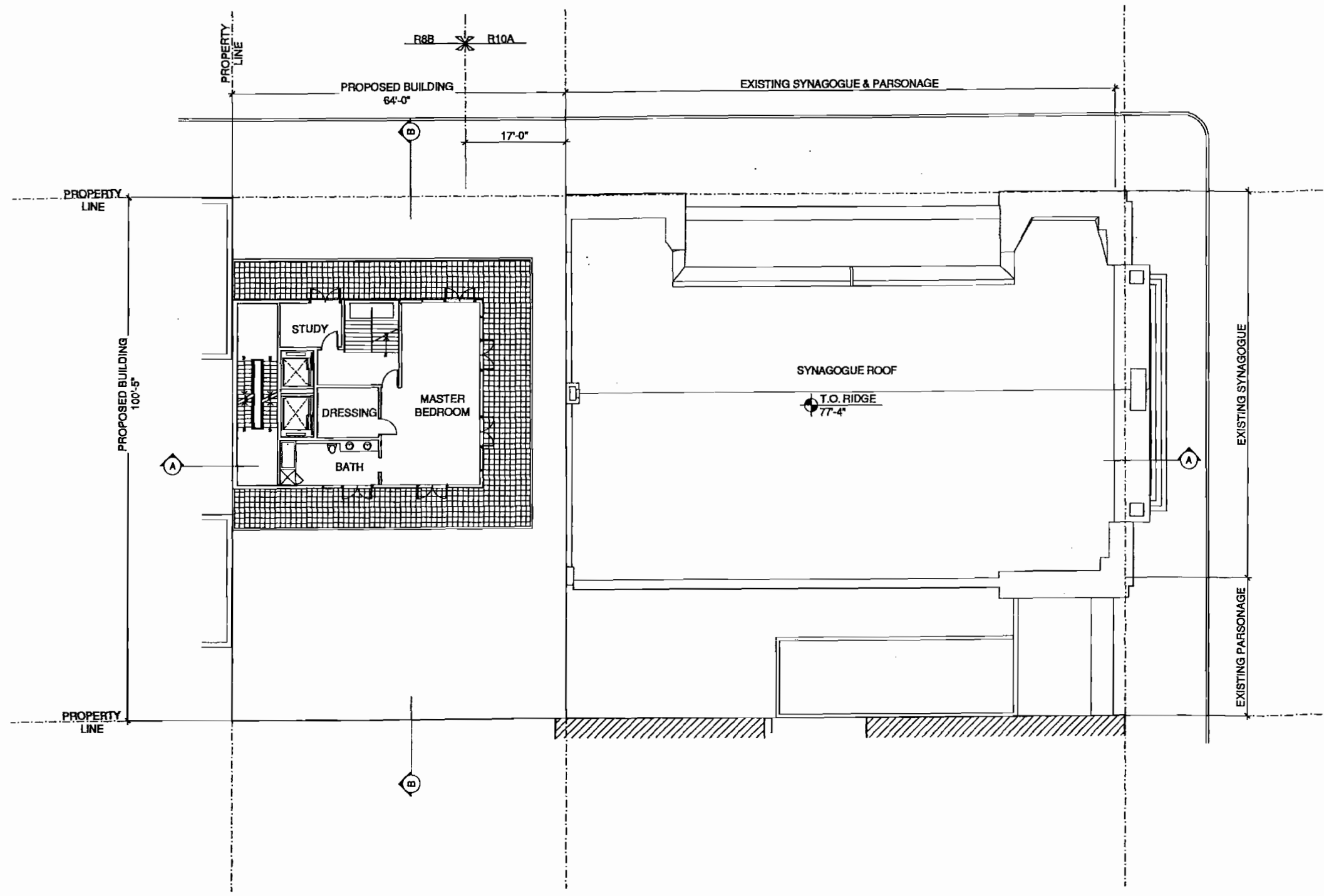

NOTE: INTERIOR PARTITIONS
FOR ILLUSTRATIVE
PURPOSES ONLY

10 WEST 70th ST.

PLATT BYARD DOVELL WHITE ARCHITECTS LLP
STEPHEN TILLY, Architect

PROPOSED PENTHOSE- UPPER LEVEL FLOOR PLAN

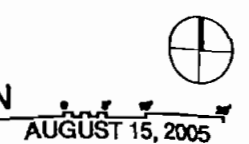

AUGUST 15, 2005

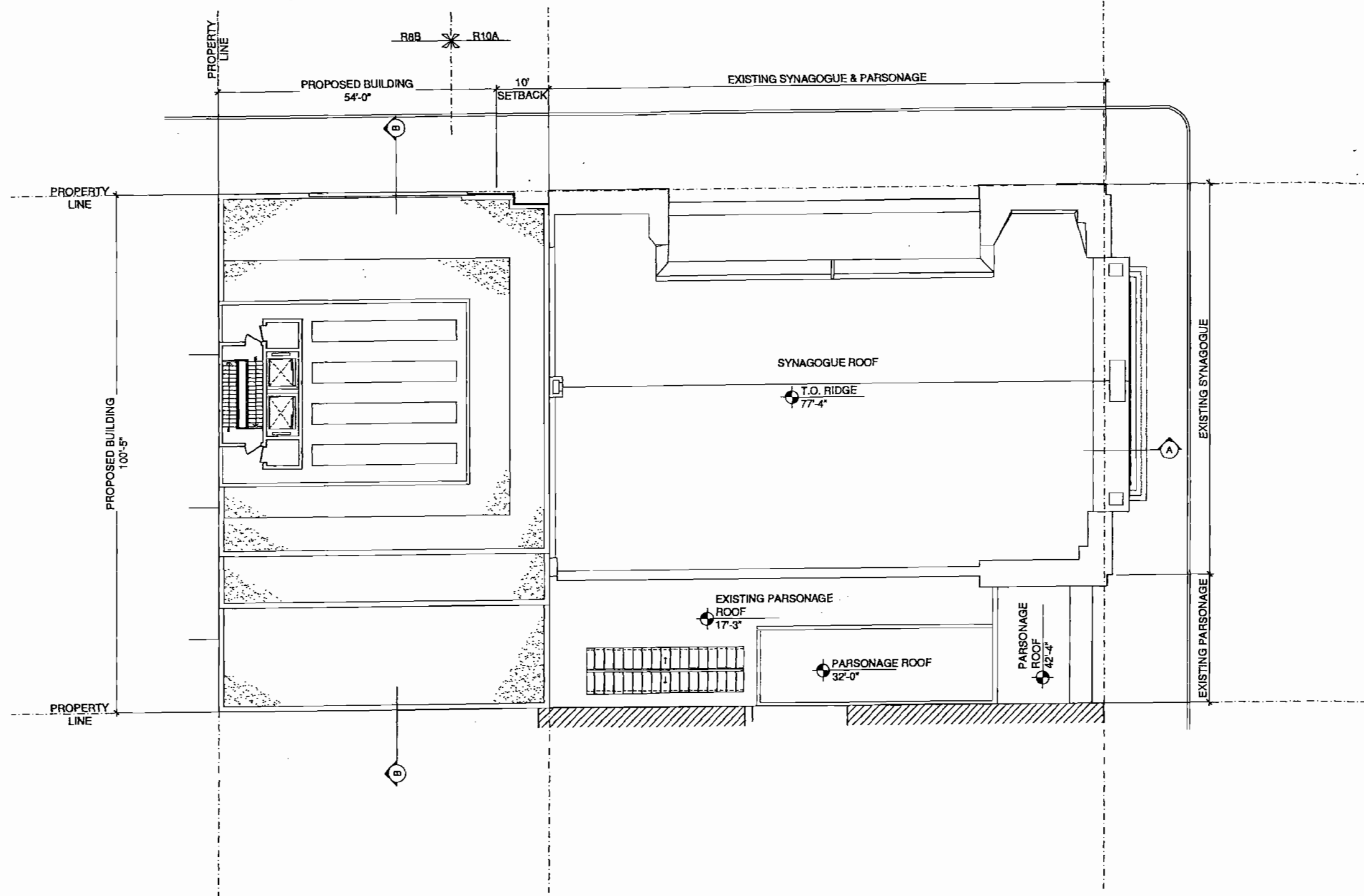

10 WEST 70th ST.
PLATT BYARD DOVELL WHITE STEPHEN TILLY, Architect
ARCHITECTS LLP

PROPOSED BULKHEAD PLAN
AUGUST 15, 2005

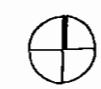

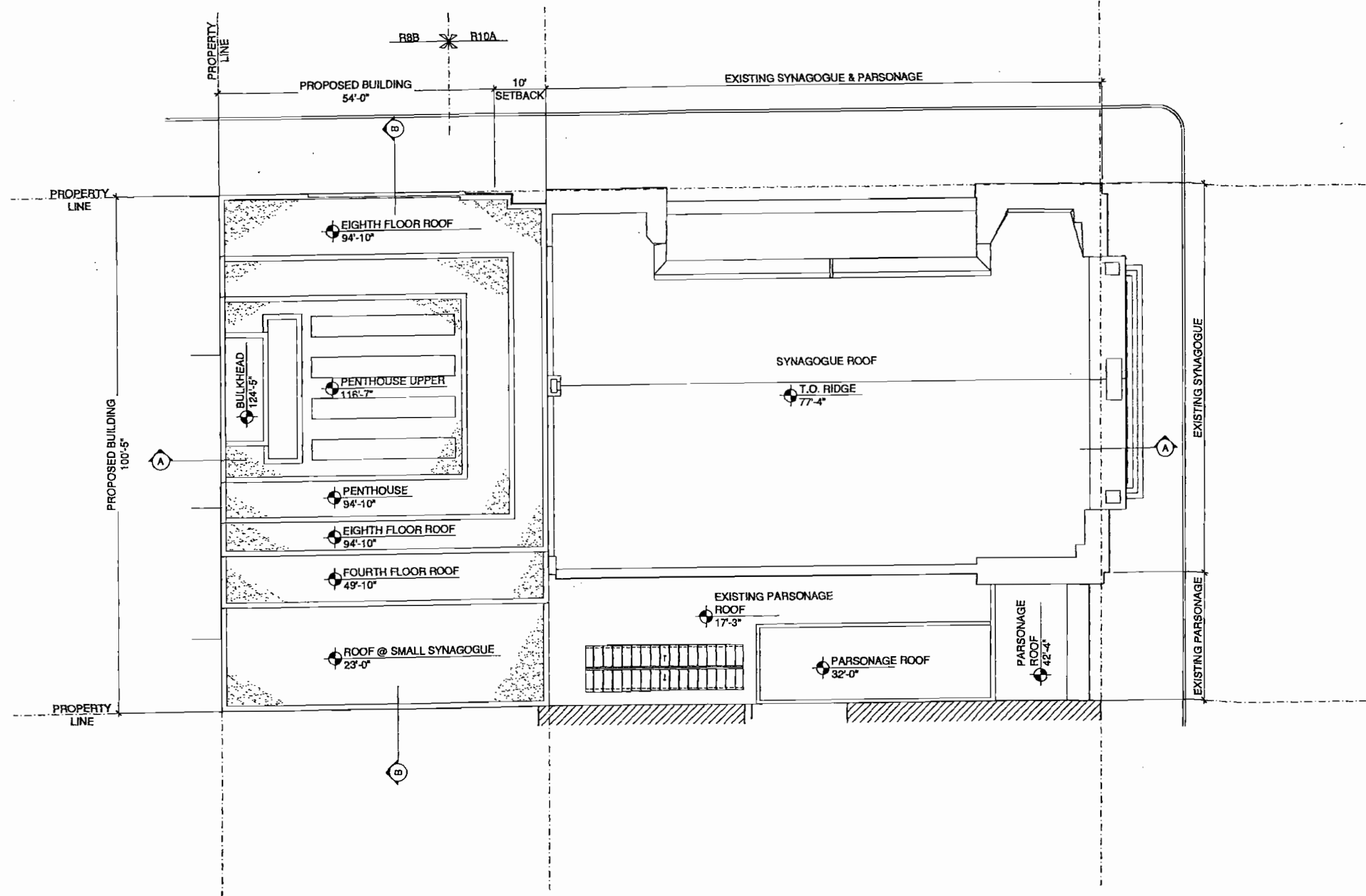

10 WEST 70th ST.

PLATT BYARD DOVELL WHITE ARCHITECTS LLP
STEPHEN TILLY, Architect

PROPOSED ROOF PLAN
AUGUST 15, 2005



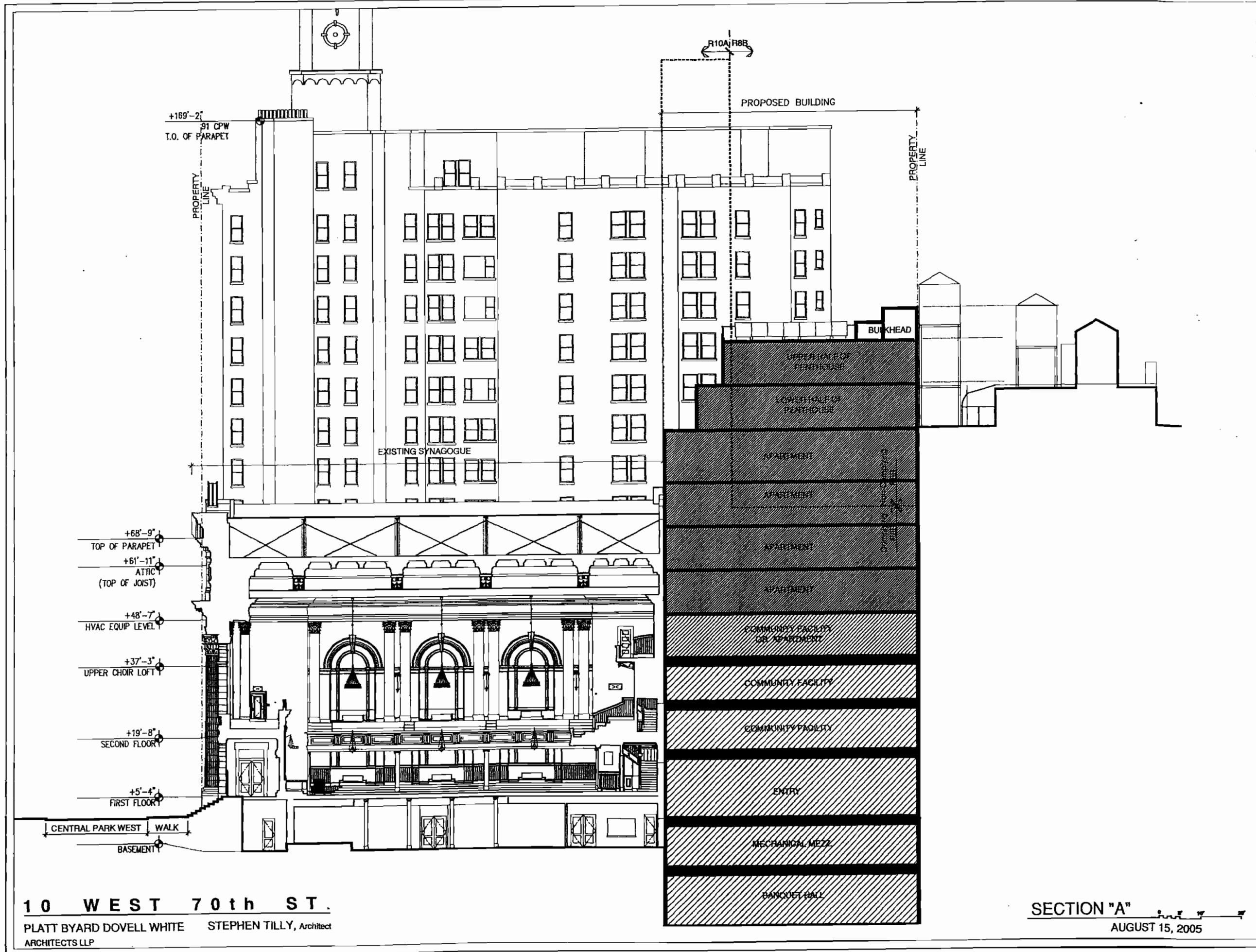

+169'-2"
91 CPW
T.O. OF PARAPET

R10A/R8B

PROPOSED BUILDING

PROPERTY LINE

PROPERTY LINE

BULKHEAD

UPPER HALF OF PENTHOUSE

LOWER HALF OF PENTHOUSE

EXISTING SYNAGOGUE

APARTMENT

APARTMENT

APARTMENT

APARTMENT

COMMUNITY FACILITY
OR APARTMENT

COMMUNITY FACILITY

COMMUNITY FACILITY

ENTRY

MECHANICAL MEZZ

BANQUET HALL

+68'-9"
TOP OF PARAPET

+61'-11"
ATTIC
(TOP OF JOIST)

+48'-7"
HVAC EQUIP LEVEL

+37'-3"
UPPER CHAIR LOFT

+19'-8"
SECOND FLOOR

+5'-4"
FIRST FLOOR

CENTRAL PARK WEST WALK

BASEMENT

10 WEST 70th ST.
 PLATT BYARD DOVELL WHITE STEPHEN TILLY, Architect
 ARCHITECTS LLP

SECTION "A"
 AUGUST 15, 2005

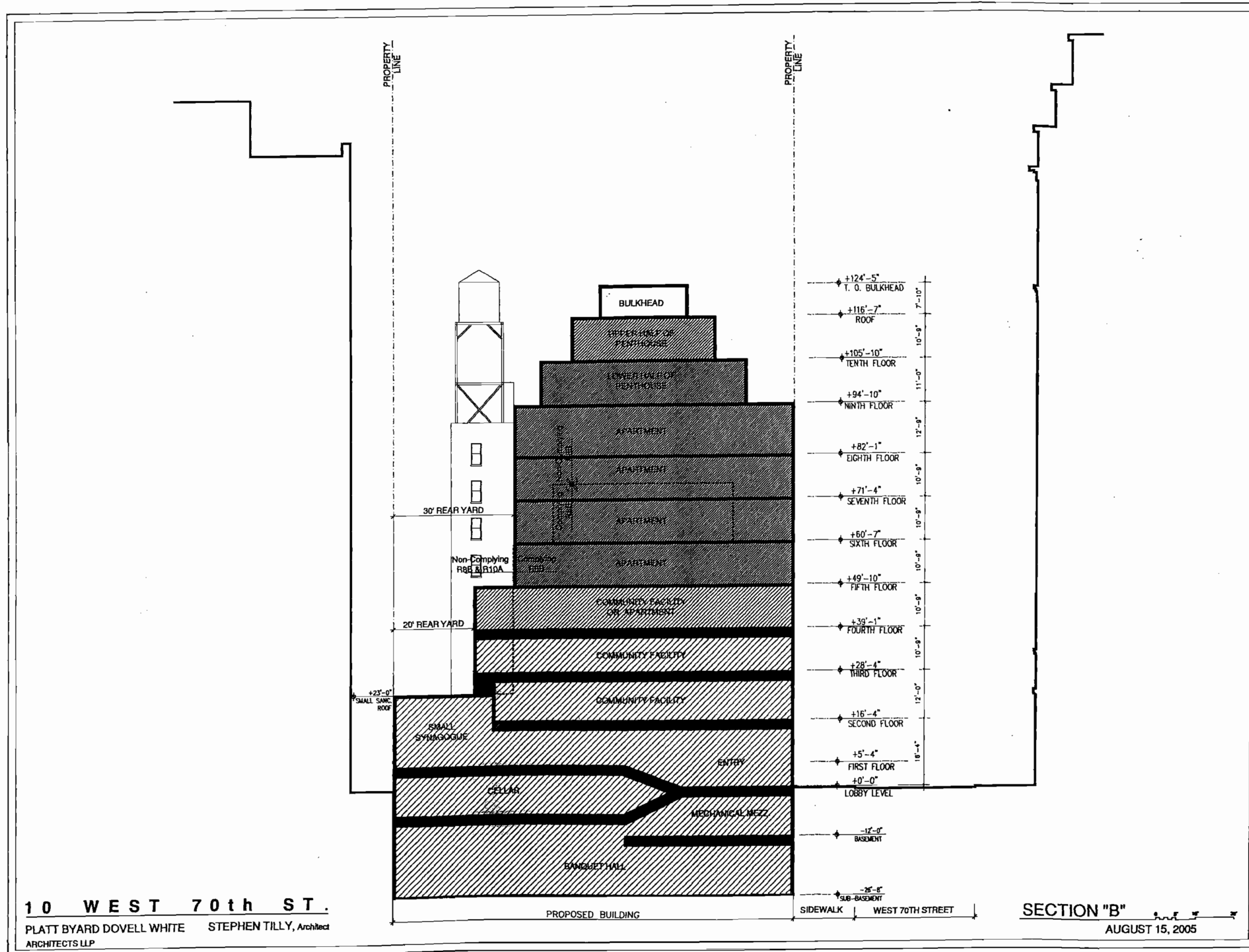

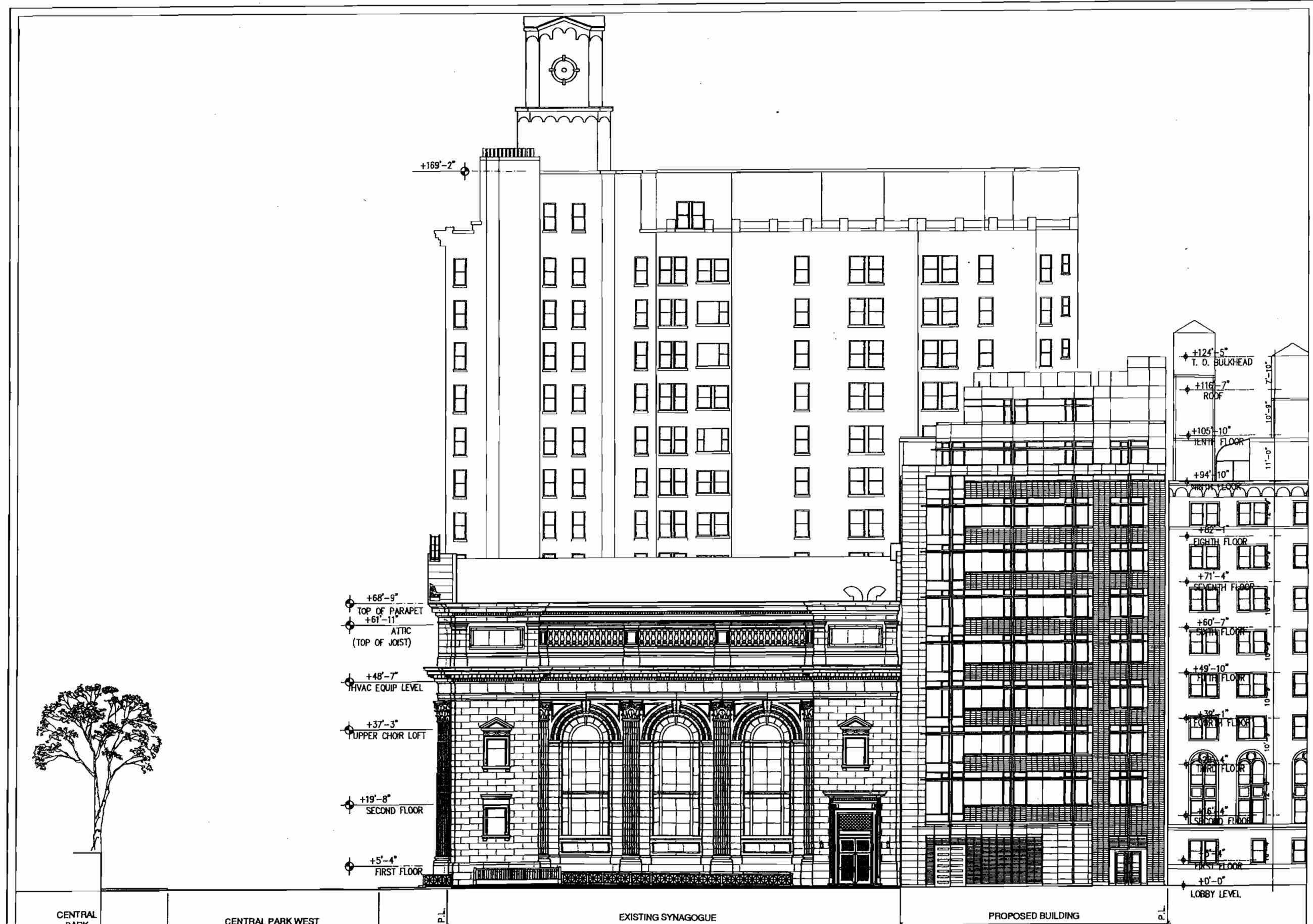

10 WEST 70th ST.
 PLATT BYARD DOVELL WHITE ARCHITECTS LLP
 STEPHEN TILLY, Architect

PROPOSED NORTH ELEVATION
 AUGUST 15, 2005

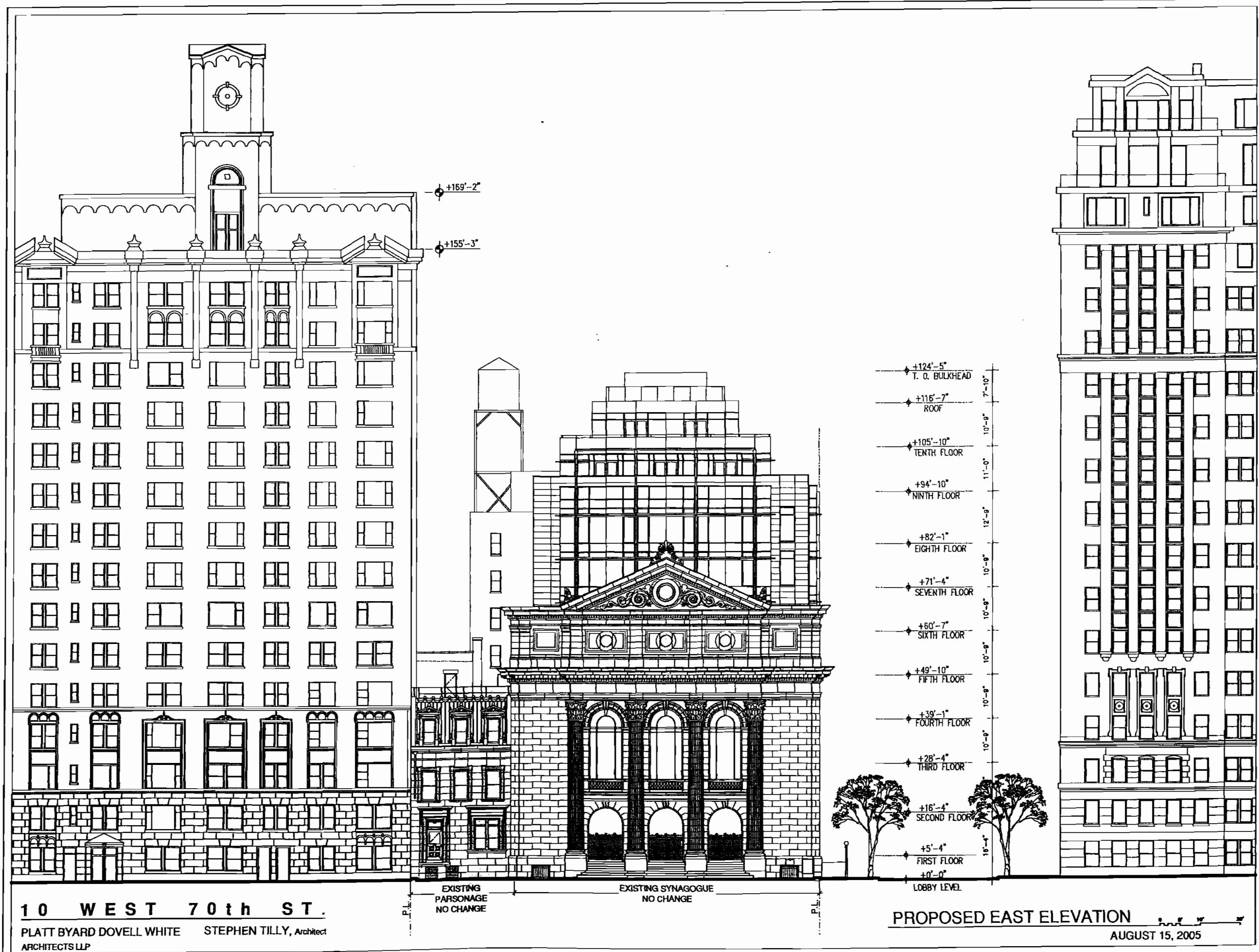

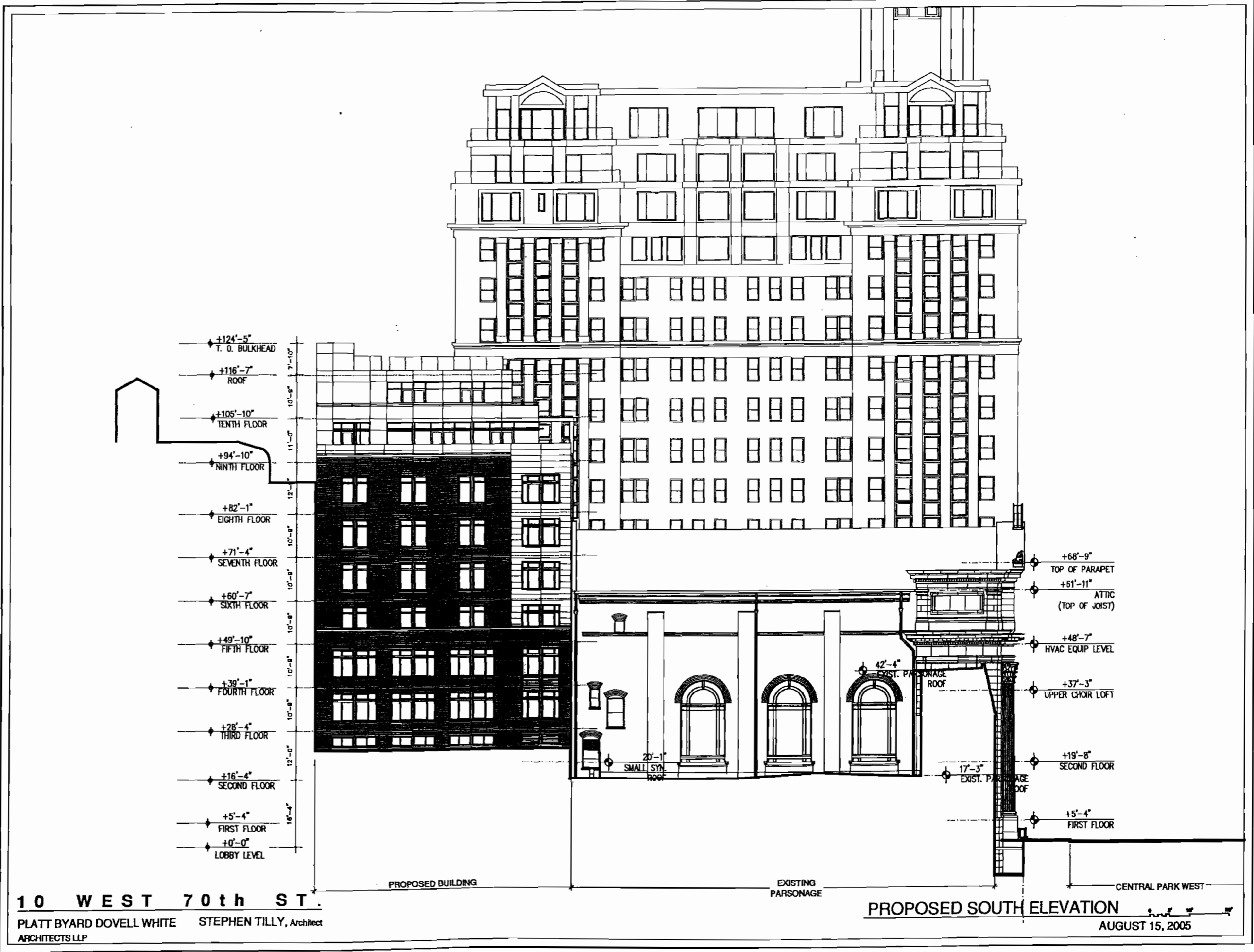

- ↕ +124'-5" T. O. BULKHEAD
- ↕ +116'-7" ROOF
- ↕ +105'-10" TENTH FLOOR
- ↕ +94'-10" NINTH FLOOR
- ↕ +82'-1" EIGHTH FLOOR
- ↕ +71'-4" SEVENTH FLOOR
- ↕ +60'-7" SIXTH FLOOR
- ↕ +49'-10" FIFTH FLOOR
- ↕ +39'-1" FOURTH FLOOR
- ↕ +28'-4" THIRD FLOOR
- ↕ +16'-4" SECOND FLOOR
- ↕ +5'-4" FIRST FLOOR
- ↕ +0'-0" LOBBY LEVEL

- ↕ +68'-9" TOP OF PARAPET
- ↕ +61'-11" ATTIC (TOP OF JOIST)
- ↕ +48'-7" HVAC EQUIP LEVEL
- ↕ +37'-3" UPPER CHOR LOFT
- ↕ +19'-8" SECOND FLOOR
- ↕ +5'-4" FIRST FLOOR

10 WEST 70th ST.
 PLATT BYARD DOVELL WHITE ARCHITECTS LLP
 STEPHEN TILLY, Architect

PROPOSED SOUTH ELEVATION
 AUGUST 15, 2005

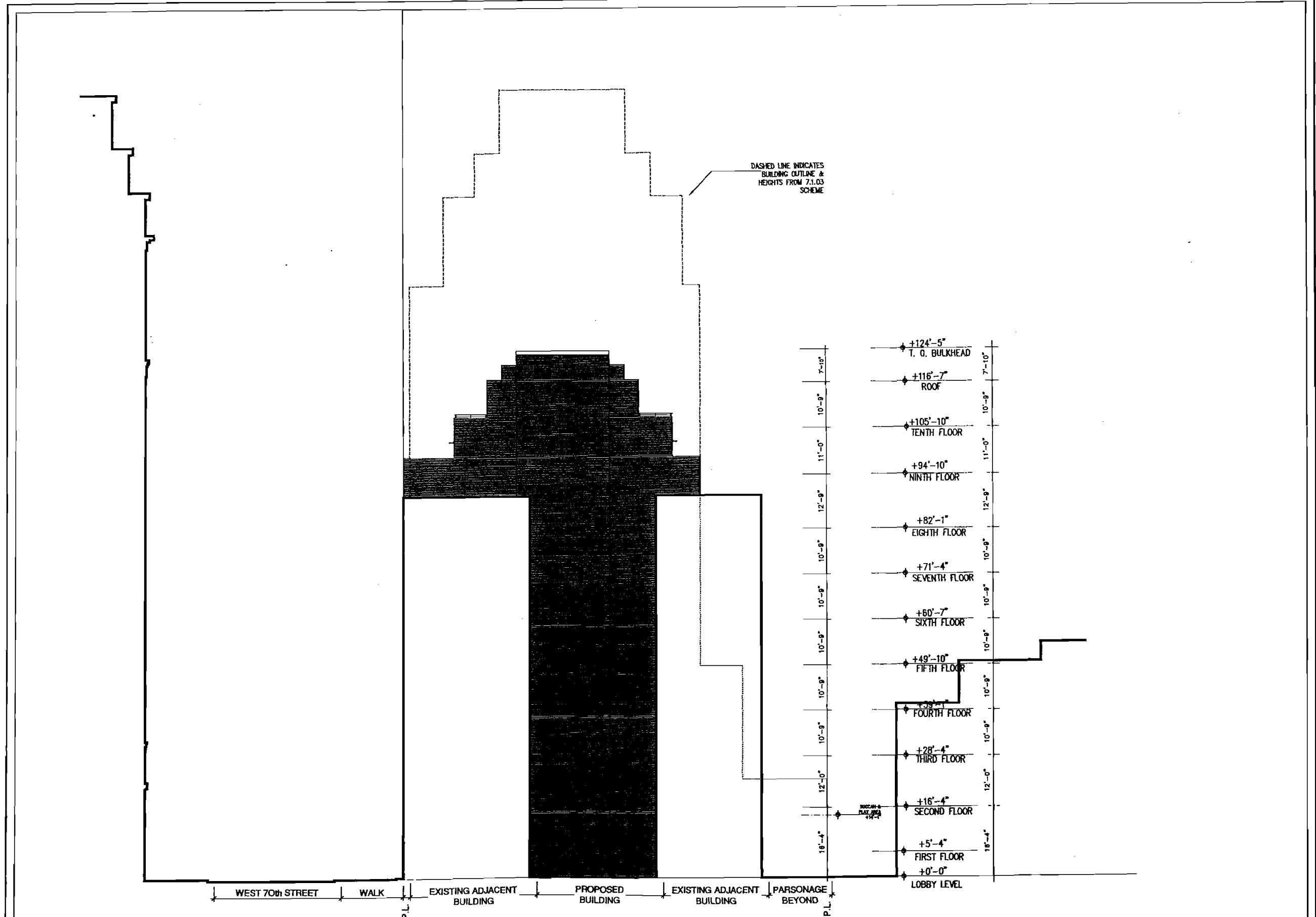

10 WEST 70th ST.

PLATT BYARD DOVELL WHITE ARCHITECTS LLP STEPHEN TILLY, Architect

PROPOSED WEST ELEVATION

AUGUST 15, 2005

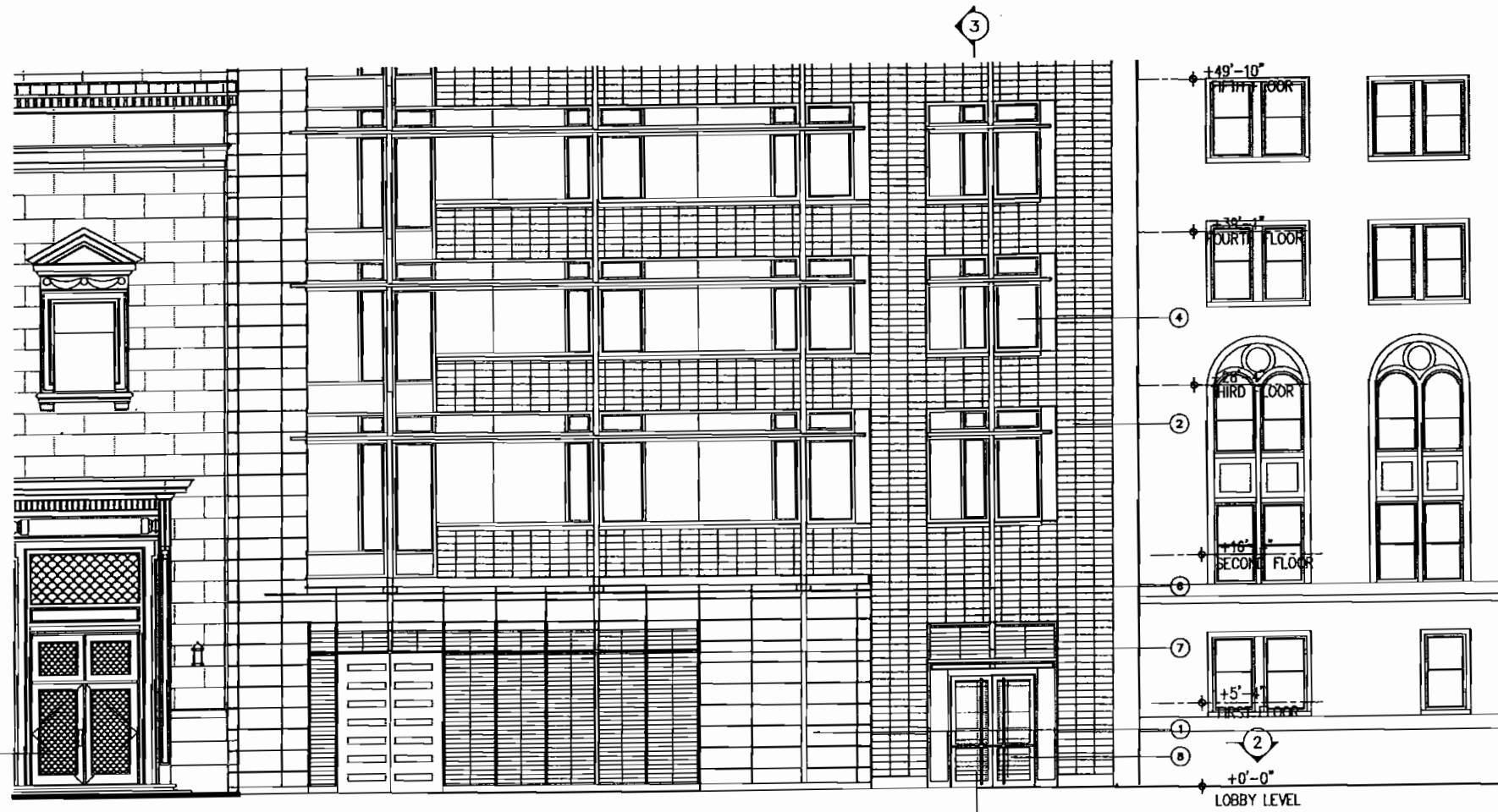

① PARTIAL NORTH ELEVATION

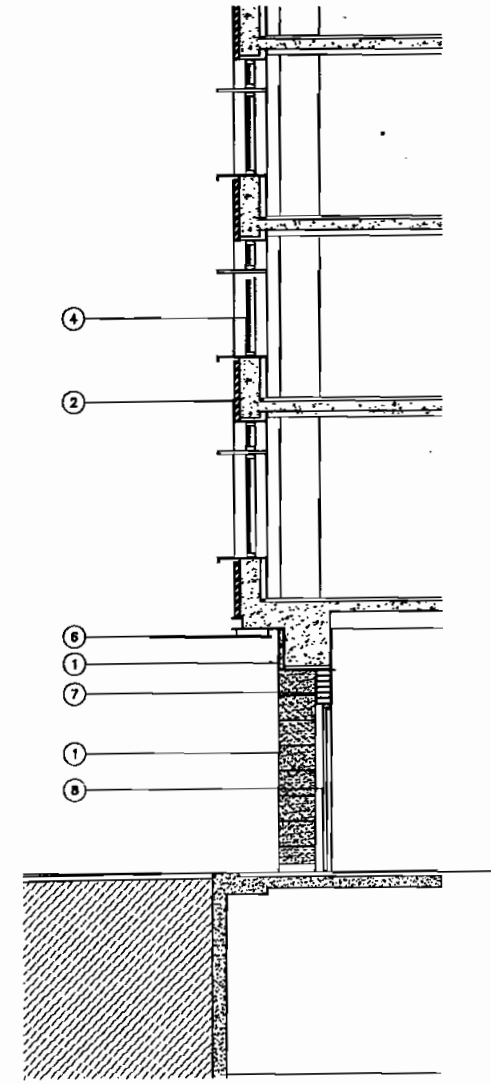

③ DETAIL SECTION AT RESIDENTIAL ENTRY

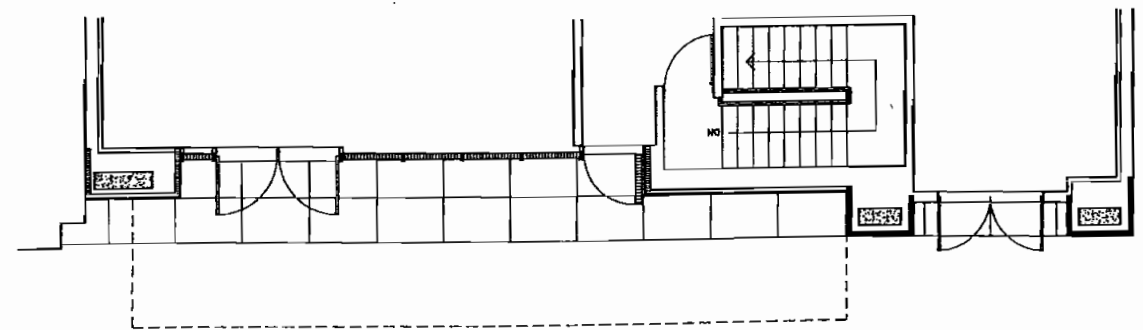

② PLAN DETAIL AT STREET LEVEL

- KEY
- 1. LIMESTONE RAINSCREEN
 - 2. PANELIZED BRICK
 - 3. METAL PANEL
 - 4. PAINTED ALUMINUM WINDOW ASSEMBLY
 - 5. PAINTED ALUMINUM AND WOOD PERGOLA
 - 6. METAL AND GLASS CANOPY
 - 7. DECORATIVE METAL SCREEN
 - 8. WOOD AND MOLDED GLASS DOORS

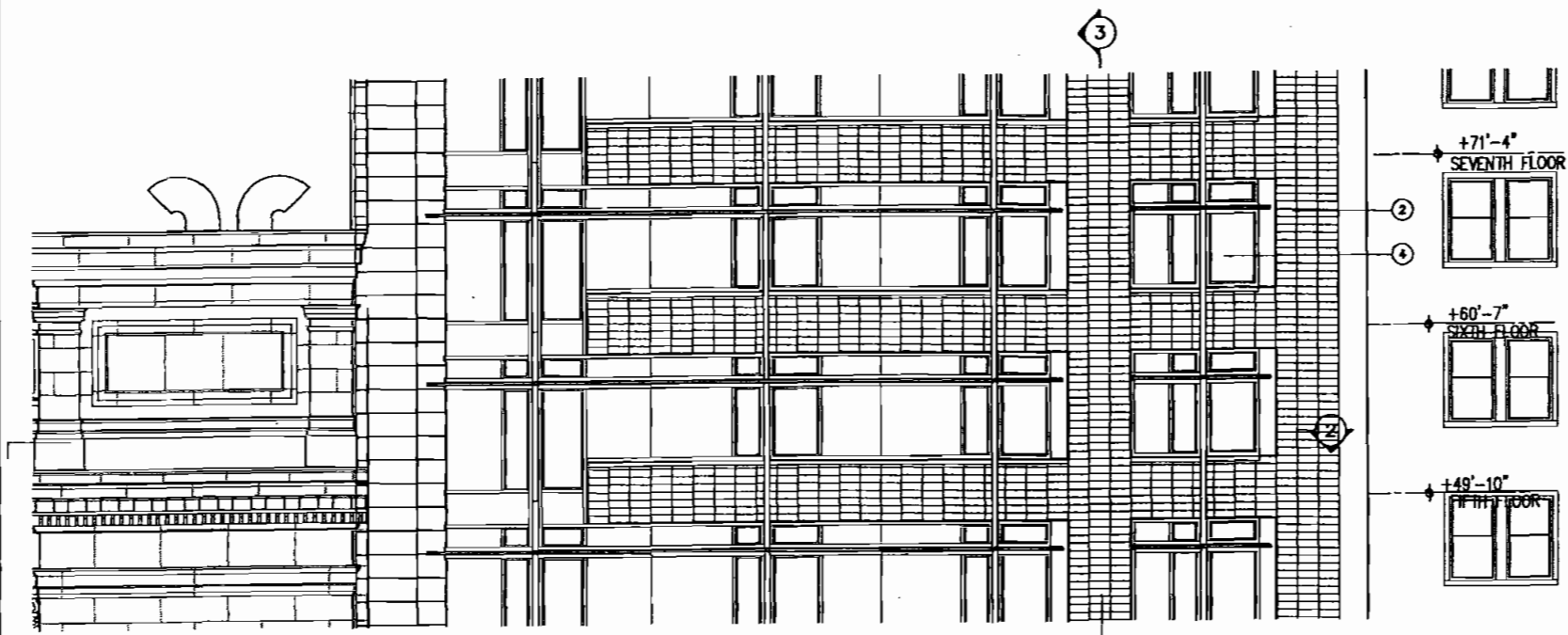

1 PARTIAL NORTH ELEVATION

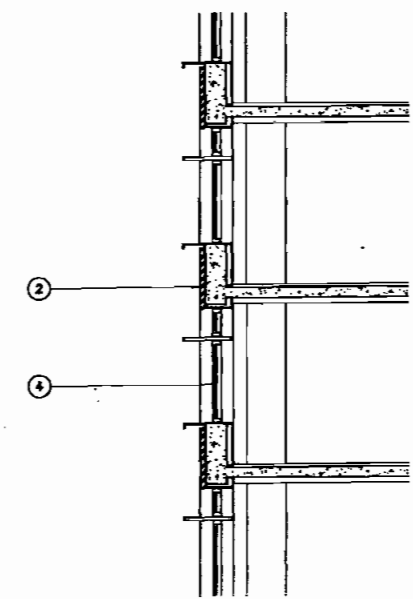

3 DETAIL SECTION

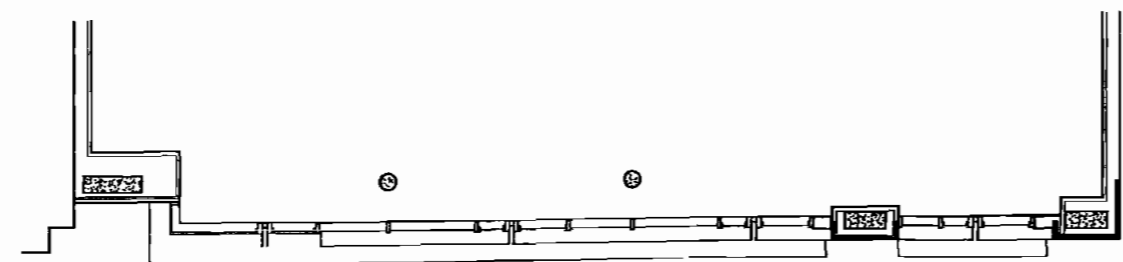

2 PLAN DETAIL AT TYPICAL FLOOR

KEY

- 1. LIMESTONE RAINSCREEN
- 2. PANELIZED BRICK
- 3. METAL PANEL
- 4. PAINTED ALUMINUM WINDOW ASSEMBLY
- 5. PAINTED ALUMINUM AND WOOD PERGOLA
- 6. METAL AND GLASS CANOPY
- 7. DECORATIVE METAL SCREEN
- 8. WOOD AND MOLDED GLASS DOORS

10 WEST 70th ST.

PLATT BYARD DOVELL WHITE STEPHEN TILLY, Architect
ARCHITECTS LLP

DETAIL PLAN/ SECTION/ ELEVATION AT MID

AUGUST 15, 2005

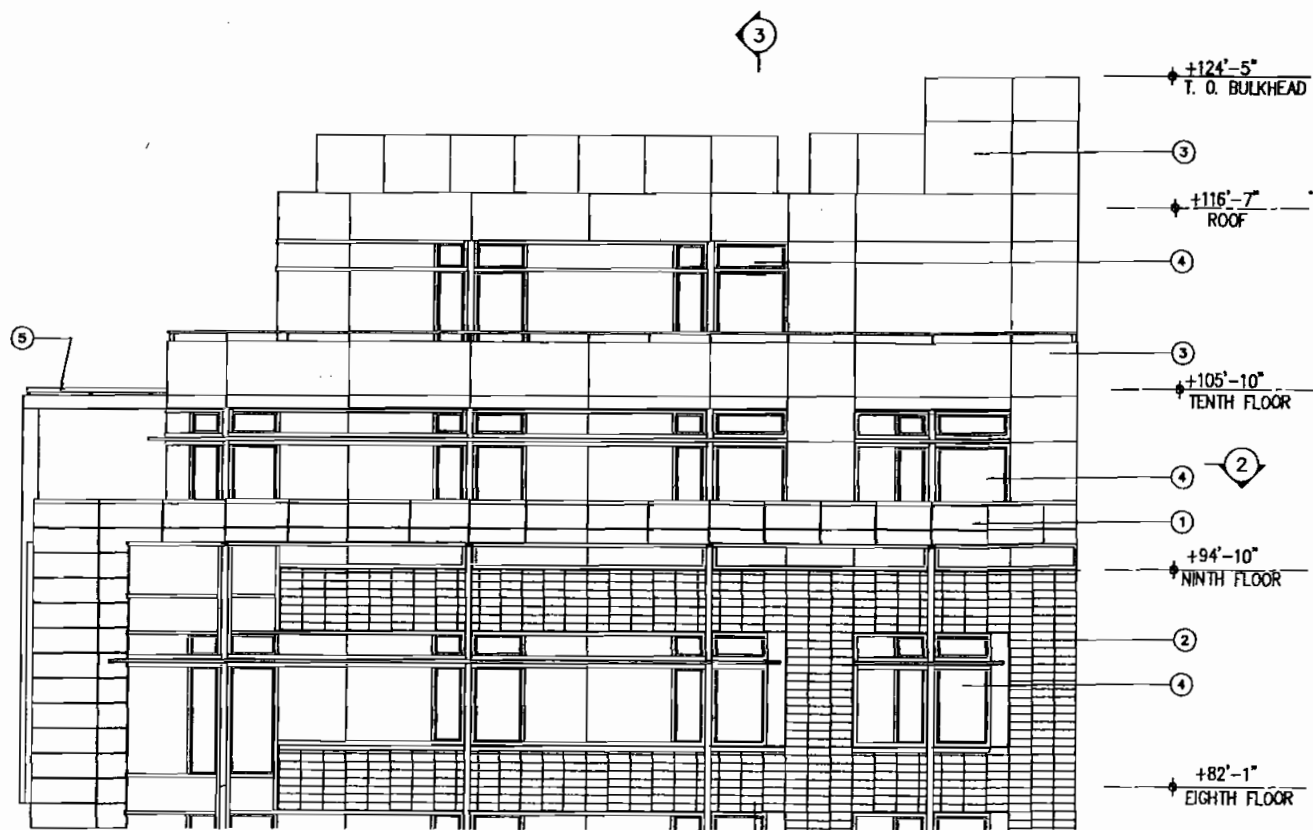

1 PARTIAL NORTH ELEVATION

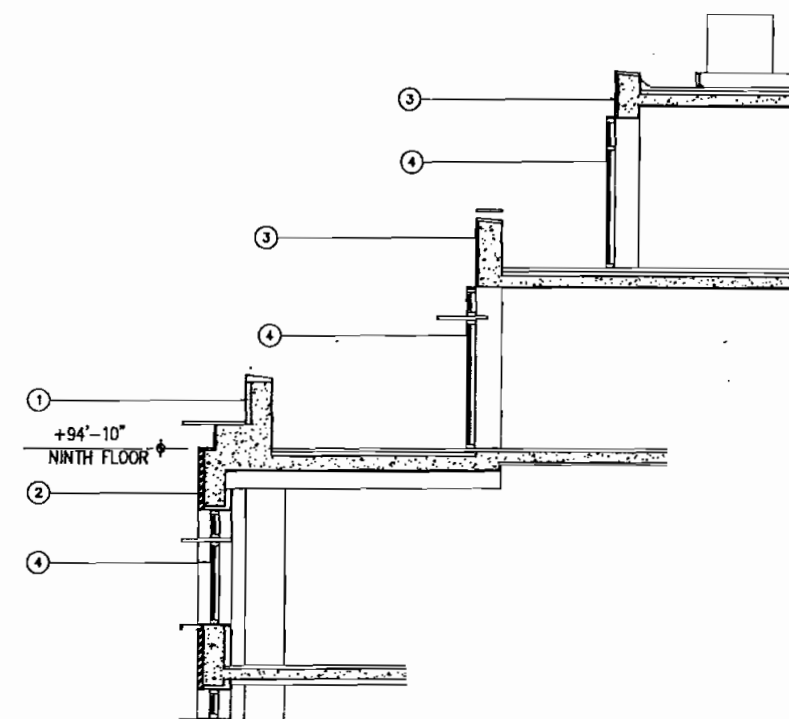

3 DETAIL SECTION

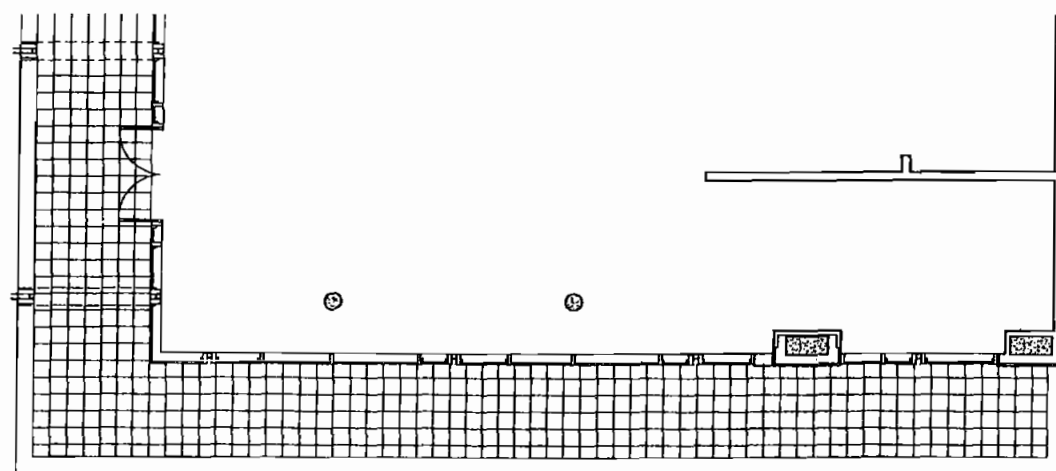

2 PLAN DETAIL AT PENTHOUSE

KEY

- 1. LIMESTONE RAINSCREEN
- 2. PANELIZED BRICK
- 3. METAL PANEL
- 4. PAINTED ALUMINUM WINDOW ASSEMBLY
- 5. PAINTED ALUMINUM AND WOOD PERGOLA
- 6. METAL AND GLASS CANOPY
- 7. DECORATIVE METAL SCREEN
- 8. WOOD AND MOLDED GLASS DOORS

10 WEST 70th ST.

PLATT BYARD DOVELL WHITE STEPHEN TILLY, Architect
ARCHITECTS LLP

DETAIL PLAN/ SECTION/ ELEVATION AT TOP

AUGUST 15, 2005



CENTRAL PARK
CENTRAL PARK WEST
PROPERTY LINE
EXISTING SYNAGOGUE
EXISTING COMM. FACILITY
VACANT LOT
PROPERTY LINE

10 WEST 70th ST.

PLATT BYARD DOVELL WHITE
ARCHITECTS LLP

EXISTING NORTH CONTEXT ELEVATION
CENTRAL PARK WEST

AUGUST 15, 2005

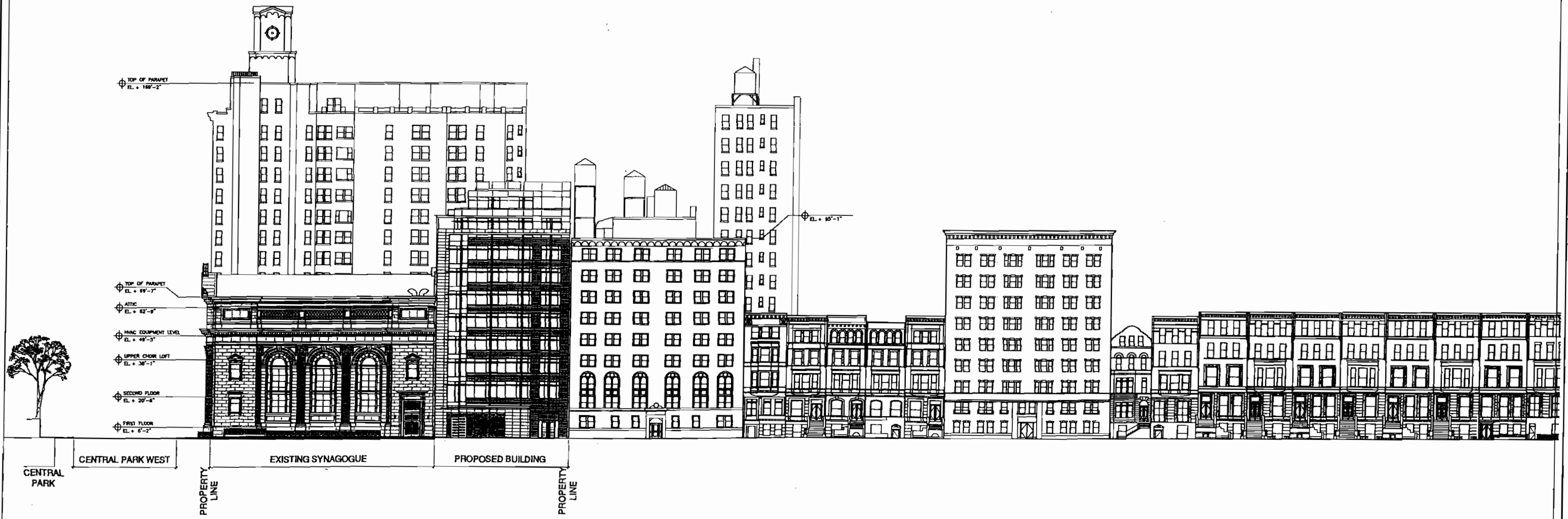

10 WEST 70th ST.

PLATT BYARD DOVELL WHITE
ARCHITECTS LLP

PROPOSED NORTH CONTEXT ELEVATION
CENTRAL PARK WEST

AUGUST 15, 2005

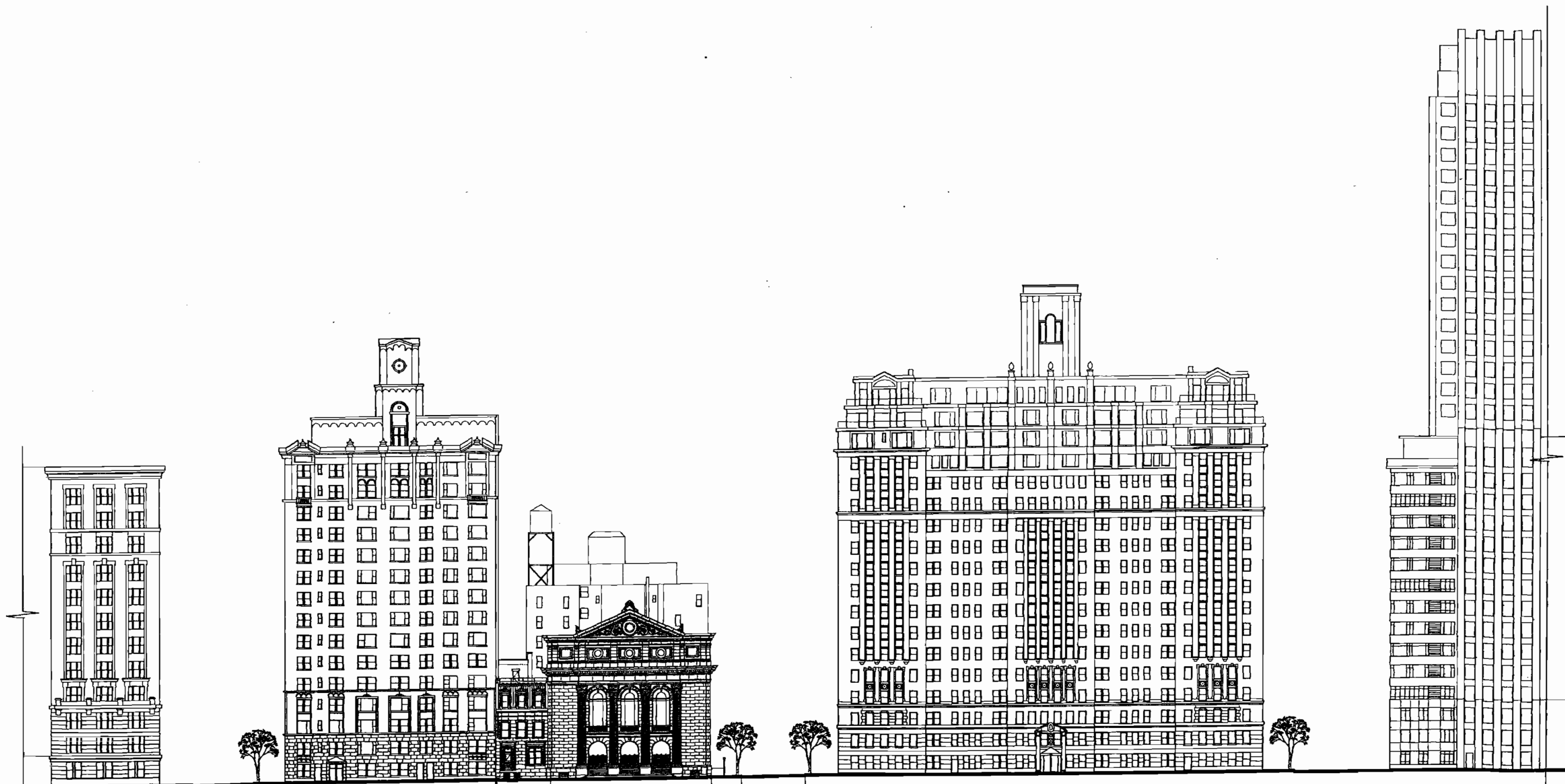

10 WEST 70th ST.

PLATT BYARD DOVELL WHITE
ARCHITECTS LLP

EXISTING EAST CONTEXT ELEVATION
CENTRAL PARK WEST

AUGUST 15, 2005

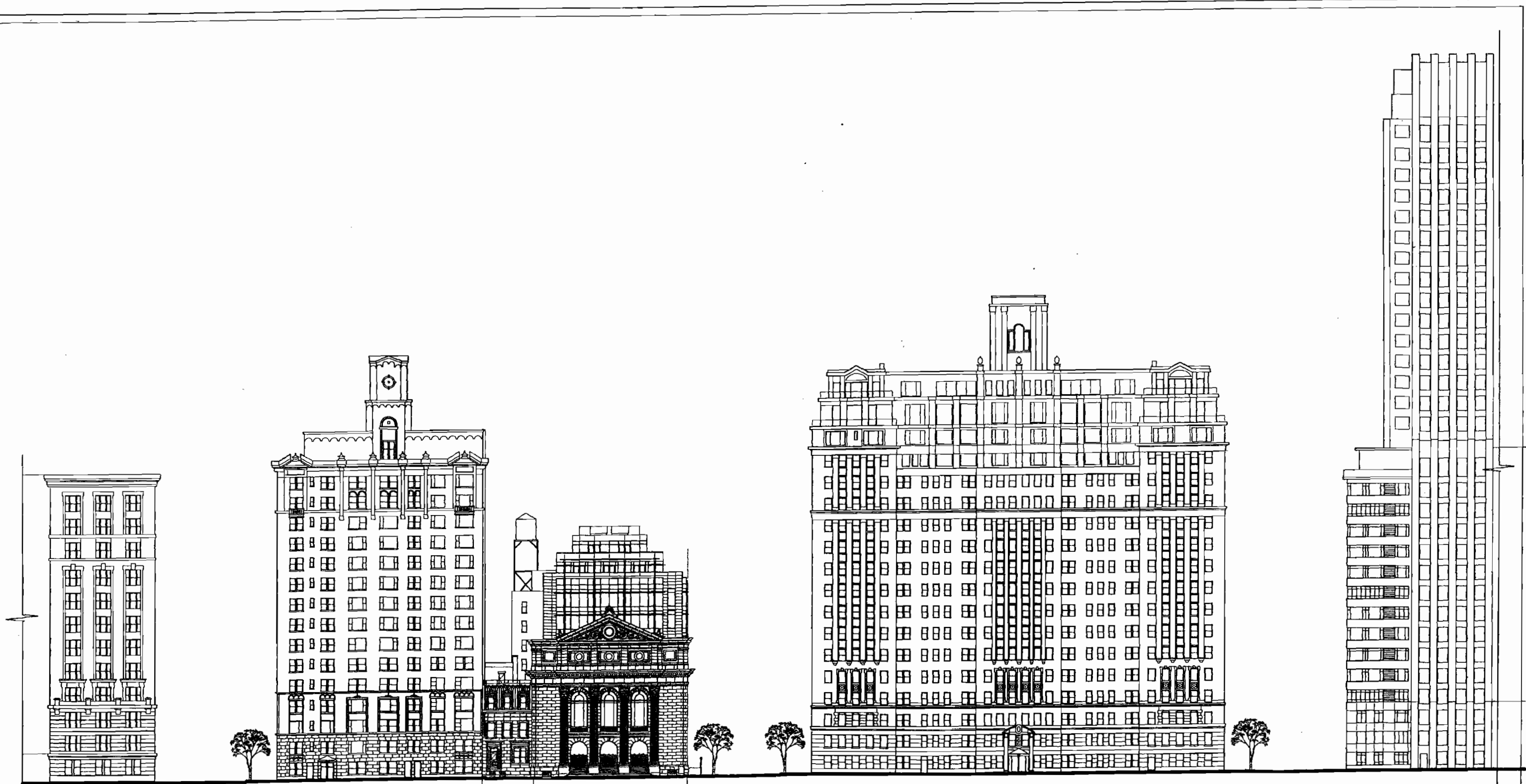

EXISTING PARSONAGE
NO CHANGE

EXISTING SYNAGOGUE
NO CHANGE

PROPERTY LINE

PROPERTY LINE

10 WEST 70th ST.

PLATT BYARD DOVELL WHITE
ARCHITECTS LLP

PROPOSED EAST CONTEXT ELEVATION
CENTRAL PARK WEST

AUGUST 15, 2005

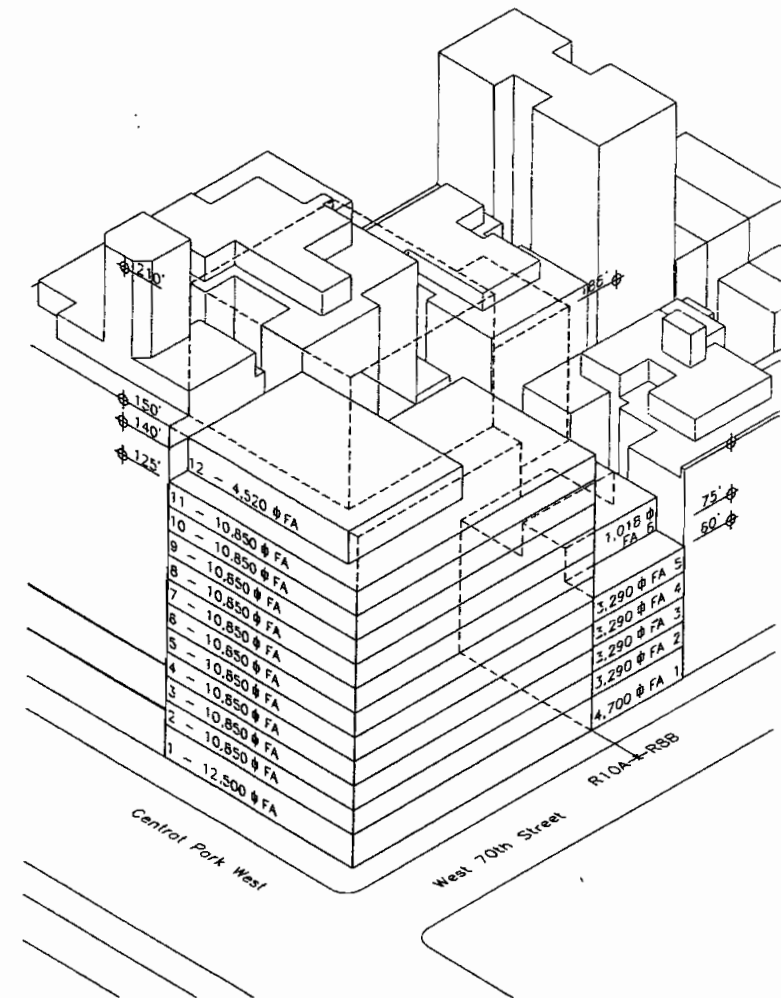
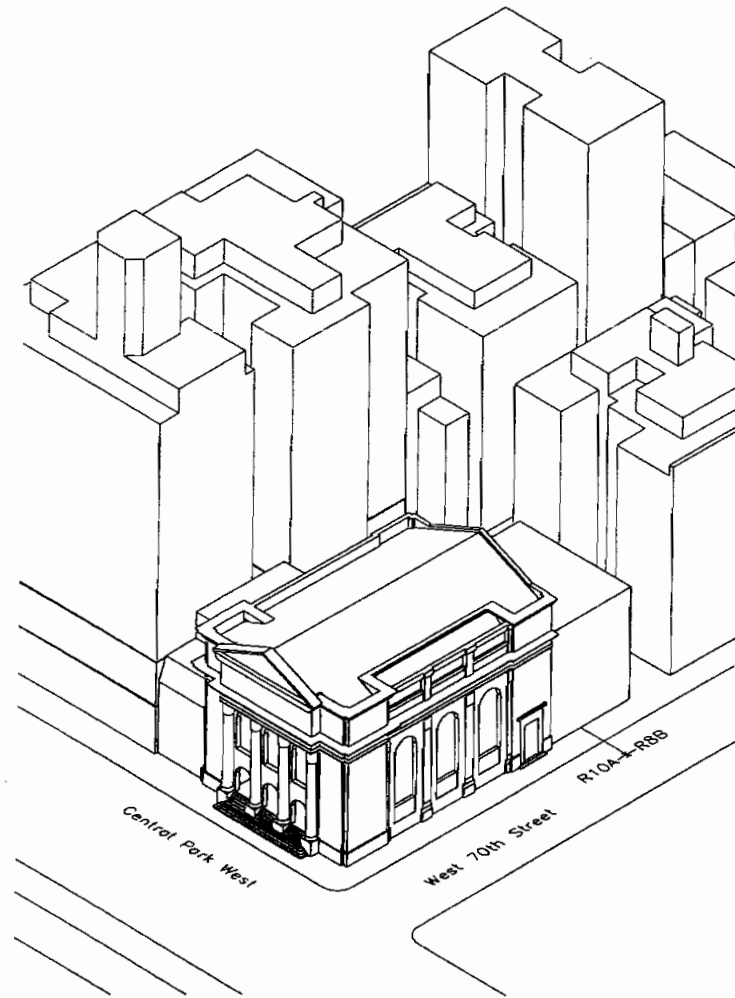
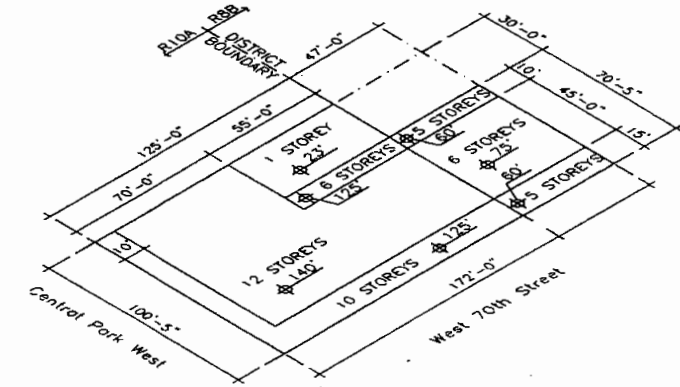
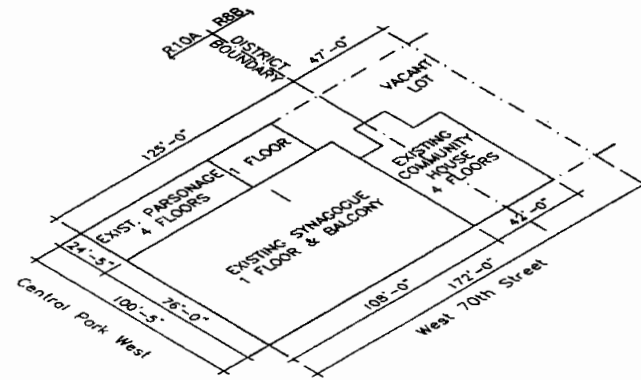

EXISTING BUILDINGS

MAXIMUM PERMITTED ZONING ENVELOPE
WITHOUT F.A.R. AVERAGING PERMITTED A.O.R. BY ZR77-22

LOT AREA: 17,272 SF
EXISTING FLOOR AREA:
R10A- 41,368 SF
R8B- 6,044 SF
COMBINED - 47,412 SF

LOT AREA: 17,272 SF
MAXIMUM FLOOR AREA:
R10A- 125, 520 SF
R8B- 18,800 SF
COMBINED - 144,400 SF

10 WEST 70th ST.

PLATT BYARD DOVELL WHITE STEPHEN TILLY, Architect
ARCHITECTS LLP

ZONING ENVELOPE

AUGUST 15, 2005

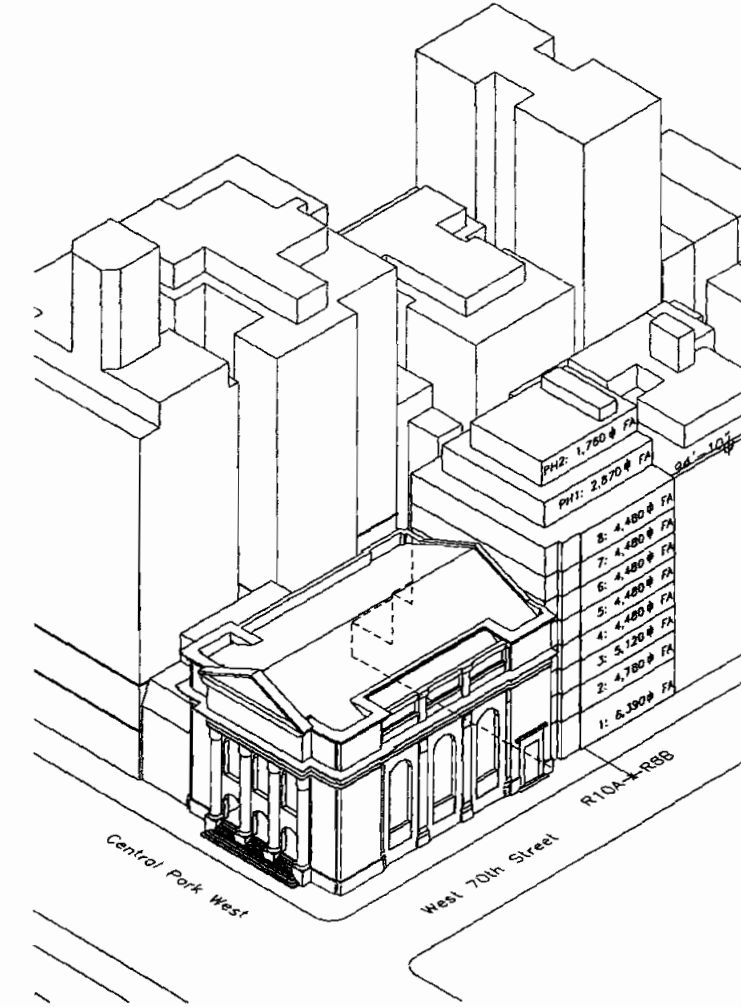
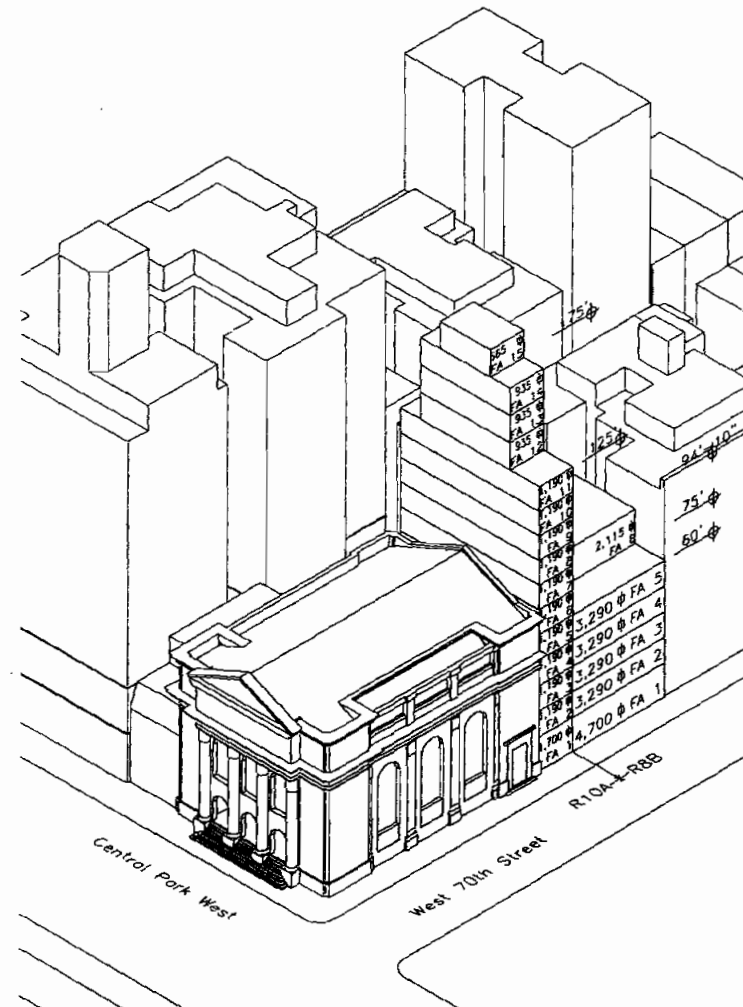
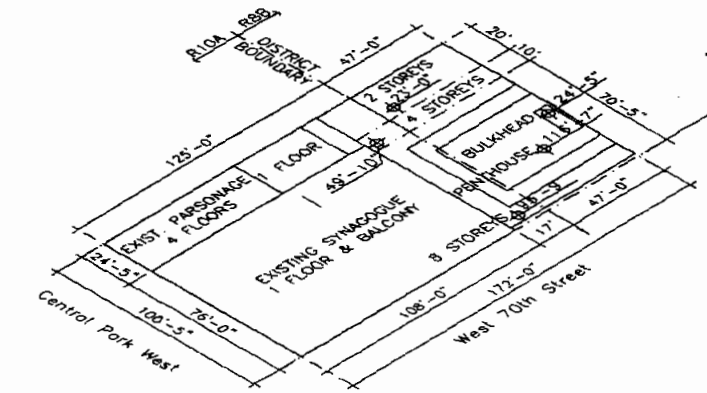
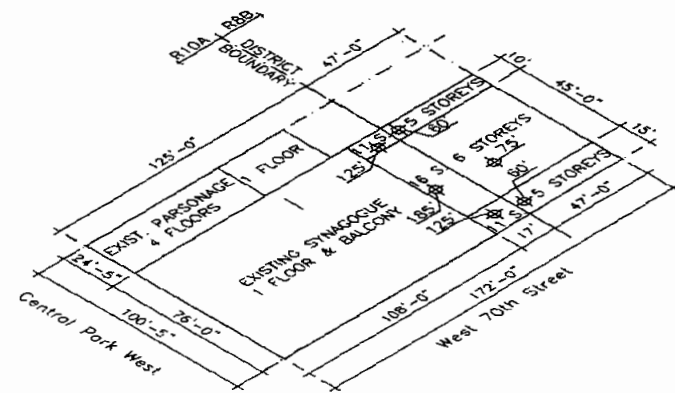

EXISTING AS OF RIGHT ZONING ENVELOPE @ DEVELOPMENT SITE

PROPOSED ZONING ENVELOPE AT DEVELOPMENT SITE

LOT AREA AT DEVELOPMENT SITE: 6,427 SF
 PERMITTED FLOOR AREA:
 R10A- 17,070 SF
 R8B- 18,878 SF
 COMBINED - 35,948 SF

PROPOSED FLOOR AREA:
 R10A- 10,980 SF
 R8B- 32,980 SF
 COMBINED - 43,960 SF

REQUIREMENTS (PRELIMINARY LIST)		
	R8B	R10A
STREET WALL HT. (MAX.)	60'	125'
BUILDING HEIGHT (MAX.)	75'	185'
LOT AREA	4,720 S.F.	1,707 S.F.
FLOOR AREA RATIO	4.00	10.00
REAR YARD	30'	30'
LOT COVERAGE (OVER 23')	70%	70%

ZONING AREAS (PROPOSED)			
FLOOR	R8B	R10A	TOTAL
1	4,670 S.F.	1,720 S.F.	6,390 S.F.
2	3,510 S.F.	1,270 S.F.	4,780 S.F.
3	3,760 S.F.	1,360 S.F.	5,120 S.F.
4	3,760 S.F.	1,360 S.F.	5,120 S.F.
5	3,290 S.F.	1,190 S.F.	4,480 S.F.
6	3,290 S.F.	1,190 S.F.	4,480 S.F.
7	3,290 S.F.	1,190 S.F.	4,480 S.F.
8	3,290 S.F.	1,190 S.F.	4,480 S.F.
PH-1	2,430 S.F.	440 S.F.	2,870 S.F.
PH-2	1,690 S.F.	70 S.F.	1,760 S.F.
TOTAL	32,980 S.F.	10,980 S.F.	43,960 S.F.

REQUIRED VARIANCES		
	R8B	R10A
PROPOSED	32,980 S.F.	10,980 S.F.
ALLOWED	18,880 S.F.	17,070 S.F.
VARIANCE REQUIRED	(-14,100 S.F.)	+6,090 S.F.

10 WEST 70th ST.

PLATT BYARD DOVELL WHITE STEPHEN TILLY, Architect
 ARCHITECTS LLP

ZONING ENVELOPE

AUGUST 15, 2005